

\$139,598.00
CONTRACTOR'S OFFICE COPY

BID OF BACHMANN CONSTRUCTION COMPANY, INC.

2022

PROPOSAL, CONTRACT, BOND AND SPECIFICATIONS

FOR

REINDAHL RESTROOM REMODEL

CONTRACT NO. 8586

PROJECT NO. 12789

MUNIS NO. 12789

IN

MADISON, DANE COUNTY, WISCONSIN

AWARDED BY THE COMMON COUNCIL
MADISON, WISCONSIN ON AUGUST 2, 2022

CITY ENGINEERING DIVISION
1600 EMIL STREET
MADISON, WISCONSIN 53713

<https://bidexpress.com/login>

**REINDAHL RESTROOM REMODEL
CONTRACT NO. 8586**

INDEX

SECTION A: ADVERTISEMENT FOR BIDS AND INSTRUCTIONS TO BIDDERS.....A-1
SECTION B: PROPOSAL SECTION.....B-1
SECTION C: SMALL BUSINESS ENTERPRISE (NOT APPLICABLE)..... C-1
SECTION D: SPECIAL PROVISIONS..... D-1
SECTION E: BIDDER'S ACKNOWLEDGEMENT.....E-1
SECTION F: BEST VALUE CONTRACTING..... F-1
SECTION G: BID BOND..... G-1
SECTION H: AGREEMENT..... H-1
SECTION I: PAYMENT AND PERFORMANCE BOND I-1

EXHIBITS FOR BIDDING PURPOSES:
EXHIBIT A – Drawings dated June 18, 2021
EXHIBIT B – Specifications dated June 18, 2021
EXHIBIT C - Existing building plans (7 shts) for Reindahl Splash Pad dated 01/23/2014

This Proposal, and Agreement have
been prepared by:

**CITY ENGINEERING DIVISION
CITY OF MADISON
MADISON, DANE COUNTY, WISCONSIN**

Kathy Cryan

Kathy Cryan, Interim Engineering Manager

KC:LA

SECTION A: ADVERTISEMENT FOR BIDS AND INSTRUCTIONS TO BIDDERS

REQUEST FOR BID FOR PUBLIC WORKS CONSTRUCTION CITY OF MADISON, WISCONSIN

A BEST VALUE CONTRACTING MUNICIPALITY

PROJECT NAME:	REINDAHL RESTROOM REMODEL
CONTRACT NO.:	8586
BID BOND	5%
PRE BID BUILDING TOUR #1 (9:00 A.M.)	JUNE 08, 2022
PRE BID BUILDING TOUR #2 (9:00 A.M.)	JUNE 14, 2022
BIDDER QUESTIONS, CLARIFICATIONS & REQUESTS FOR SBUSTITUTIONS	JUNE 23, 2022
PREQUALIFICATION APPLICATION DUE (2:00 P.M.)	June 30, 2022
BID SUBMISSION (2:00 P.M.)	July 07, 2022
BID OPEN (2:30 P.M.)	July 07, 2022
PUBLISHED IN WSJ	MAY 26, JUN 2, JUN 9, JUN 16, JUN 23 & JUN 30

PRE BID BUILDING TOUR: The City of Madison is conducting two (2) Pre-Bid Walk Building Tour sessions at the existing concessions/pump room building of the Reindahl Park Splash Pad, 1818 Portage Road, Madison, WI, as indicated in the chart above. All contractors are invited to attend a short introductory meeting, a short guided tour of the project area, and then will be allowed to more thoroughly review the project area at their own pace. Please refer to the schedule table above for Building Tour dates and times.

These are the only times contractors shall be allowed access to the interior spaces of the building. Contractors may review exterior public areas at any time during normal business day hours.

City Staff will be in attendance to take questions related to the plans and specifications. Questions shall be recorded and responded to in the form of a published addendum.

BIDDER QUESTIONS, CLARIFICATIONS, AND REQUESTS FOR SUBSTITUTIONS:

If needed, the City Project Manager (CPM) shall publish addenda to respond to any questions, clarifications, or requests for substitutions.

- Any questions or requests for clarifications regarding plans and specifications shall be submitted directly to the CPM. See contact information at the end of Section D – Special Provisions. Responses that change the contract scope and/or schedule will be published by the CPM in the form of a published bidding addendum.
- Requests for substitutions shall be done according to Specification 00 43 25 Substitution Request Form (During Bidding) and other specifications as necessary. Use the form at the end of the specification. Contractors are cautioned to review all specifications and note whether substitutions for specific products will be allowed or not.
- See the contract contact information at the end of Section D-Special Provisions for contact information. All questions and/or substitution requests shall be sent via email with reference to Reindahl Restroom Remodel 8586 in the subject line.
- **The deadline for receiving all questions, clarifications, and requests for substitutions shall be as indicated in the schedule table above.**

PUBLISHING ADDENDUMS:

The City of Madison shall publish bidding addenda as needed during the bidding period. The last addenda (if needed) shall be published on or about 12:00PM, Tuesday, July 05, 2022 to give all contractors sufficient time to review the addenda before bids are due. The City of Madison reminds all

General Contractors that you must acknowledge having read all addenda when submitting your bid. Failure to acknowledge all addenda shall disqualify your bid.

PREQUALIFICATION APPLICATION: Forms are available at the same location or on our website, www.cityofmadison.com/engineering/developers-contractors/contractors/how-to-get-prequalified. If not currently prequalified in the categories listed in Section A, an amendment to your Prequalification will need to be submitted prior to the same due date. Postmark is not applicable.

BIDS TO BE SUBMITTED: Bids may be submitted on line at www.bidexpress.com, or by hand at 1600 Emil St. The bids will be posted online after the bid opening. If you have any questions, please call Alane Boutelle at (608) 267-1197, or John Fahrney, (608) 266-9091.

STANDARD SPECIFICATIONS

The City of Madison's Standard Specifications for Public Works Construction - 2022 Edition, as supplemented and amended from time to time, forms a part of these contract documents as if attached hereto.

These standard specifications are available on the City of Madison Public Works website, www.cityofmadison.com/engineering/developers-contractors/standard-specifications.

The Contractor shall review these Specifications prior to preparation of proposals for the work to be done under this contract, with specific attention to Article 102, "BIDDING REQUIREMENTS AND CONDITIONS" and Article 103, "AWARD AND EXECUTION OF THE CONTRACT." For the convenience of the bidder, below are highlights of three subsections of the specifications.

SECTION 102.1: PRE-QUALIFICATION OF BIDDERS

In accordance with Wisconsin State Statutes 66.0901 (2) and (3), all bidders must submit to the Board of Public Works proof of responsibility on forms furnished by the City. The City requires that all bidders be qualified on a biennial basis.

Bidders must present satisfactory evidence that they have been regularly engaged in the type of work specified herein and they are fully prepared with necessary capital, materials, machinery and supervisory personnel to conduct the work to be contracted for to the satisfaction of the City. All bidders must be pre-qualified by the Board of Public Works for the type of construction on which they are bidding prior to the opening of the bid.

In accordance with Section 39.02(9)(a). of the General Ordinances, all bidders shall submit in writing to the Affirmative Action Division Manager of the City of Madison, a Certificate of Compliance or an Affirmative Action Plan at the same time or prior to the submission of the proof of responsibility forms.

The bidder shall be disqualified if the bidder fails to or refuses to, prior to opening of the bid, submit a Certificate of compliance, Affirmative Action Plan or Affirmative Action Data Update, as applicable, as defined by Section 39.02 of the General Ordinances (entitled Affirmative Action) and as required by Section 102.11 of the Standard Specifications.

SECTION 102.4 PROPOSAL

No bid will be accepted that does not contain an adequate or reasonable price for each and every item named in the Schedule of Unit Prices.

A lump sum bid for the work in accordance with the plans and specifications is required. The lump sum bid must be the same as the total amounts bid for the various items and it shall be inserted in the space provided.

All papers bound with or attached to the proposal form are considered a part thereof and must not be detached or altered when the proposal is submitted. The plans, specifications and other documents designated in the proposal form will be considered a part of the proposal whether attached or not.

A proposal submitted by an individual shall be signed by the bidder or by a duly authorized agent. A proposal submitted by a partnership shall be signed by a member/partner or by a duly authorized agent thereof. A proposal submitted by a corporation shall be signed by an authorized officer or duly authorized registered agent of such corporation, and the proposal shall show the name of the State under the laws of which such corporation was chartered. The required signatures shall in all cases appear in the space provided thereof on the proposal.

Each proposal shall be placed, together with the proposal guaranty, in a sealed envelope, so marked as to indicate name of project, the contract number or option to which it applies, and the name and address of the Contractor or submitted electronically through Bid Express (www.bidexpress.com). Proposals will be accepted at the location, the time and the date designated in the advertisement. Proposals received after the time and date designated will be returned to the bidder unopened.

SECTION 102.5: BID DEPOSIT (PROPOSAL GUARANTY)

All bids, sealed or electronic, must be accompanied with a Bid Bond (City of Madison form) equal to at least 5% of the bid or a Certificate of Annual/Biennial Bid Bond or certified check, payable to the City Treasurer. Bid deposit of the successful bidders shall be returned within forty-eight (48) hours following execution of the contract and bond as required.

MINOR DISCREPENCIES

Bidder is responsible for submitting all forms necessary for the City to determine compliance with State and City bidding requirements. Notwithstanding any language to the contrary contained herein, the City may exercise its discretion to allow bidders to correct or supplement submissions after bid opening, if the minor discrepancy, bid irregularity or omission is insignificant and not one related to price, quality, quantity, time of completion or performance of the contract.

Bidders for this Contract(s) must be Pre-Qualified for at least one of the following type(s) of construction denoted by an

Building Demolition

- 101 Asbestos Removal
- 120 House Mover

- 110 Building Demolition

Street, Utility and Site Construction

- 201 Asphalt Paving
- 205 Blasting
- 210 Boring/Pipe Jacking
- 215 Concrete Paving
- 220 Con. Sidewalk/Curb & Gutter/Misc. Flat Work
- 221 Concrete Bases and Other Concrete Work
- 222 Concrete Removal
- 225 Dredging
- 230 Fencing
- 235 Fiber Optic Cable/Conduit Installation
- 240 Grading and Earthwork
- 241 Horizontal Saw Cutting of Sidewalk
- 242 Hydro Excavating
- 243 Infrared Seamless Patching
- 245 Landscaping, Maintenance
- 246 Ecological Restoration
- 250 Landscaping, Site and Street
- 251 Parking Ramp Maintenance
- 252 Pavement Marking
- 255 Pavement Sealcoating and Crack Sealing
- 260 Petroleum Above/Below Ground Storage Tank Removal/Installation
- 262 Playground Installer

- 265 Retaining Walls, Precast Modular Units
- 270 Retaining Walls, Reinforced Concrete
- 275 Sanitary, Storm Sewer and Water Main Construction
- 276 Sawcutting
- 280 Sewer Lateral Drain Cleaning/Internal TV Insp.
- 285 Sewer Lining
- 290 Sewer Pipe Bursting
- 295 Soil Borings
- 300 Soil Nailing
- 305 Storm & Sanitary Sewer Laterals & Water Svc.
- 310 Street Construction
- 315 Street Lighting
- 318 Tennis Court Resurfacing
- 320 Traffic Signals
- 325 Traffic Signing & Marking
- 332 Tree pruning/removal
- 333 Tree, pesticide treatment of
- 335 Trucking
- 340 Utility Transmission Lines including Natural Gas, Electrical & Communications
- 399 Other _____

Bridge Construction

- 501 Bridge Construction and/or Repair

Building Construction

- 401 Floor Covering (including carpet, ceramic tile installation, rubber, VCT)
- 402 Building Automation Systems
- 403 Concrete
- 404 Doors and Windows
- 405 Electrical - Power, Lighting & Communications
- 410 Elevator - Lifts
- 412 Fire Suppression
- 413 Furnishings - Furniture and Window Treatments
- 415 General Building Construction, Equal or Less than \$250,000
- 420 General Building Construction, \$250,000 to \$1,500,000
- 425 General Building Construction, Over \$1,500,000
- 428 Glass and/or Glazing
- 429 Hazardous Material Removal
- 430 Heating, Ventilating and Air Conditioning (HVAC)
- 433 Insulation - Thermal
- 435 Masonry/Tuck pointing

- 437 Metals
- 440 Painting and Wallcovering
- 445 Plumbing
- 450 Pump Repair
- 455 Pump Systems
- 460 Roofing and Moisture Protection
- 464 Tower Crane Operator
- 461 Solar Photovoltaic/Hot Water Systems
- 465 Soil/Groundwater Remediation
- 466 Warning Sirens
- 470 Water Supply Elevated Tanks
- 475 Water Supply Wells
- 480 Wood, Plastics & Composites - Structural & Architectural
- 499 Other _____

State of Wisconsin Certifications

- 1 Class 5 Blaster - Blasting Operations and Activities 2500 feet and closer to inhabited buildings for quarries, open pits and road cuts.
- 2 Class 6 Blaster - Blasting Operations and Activities 2500 feet and closer to inhabited buildings for trenches, site excavations, basements, underwater demolition, underground excavations, or structures 15 feet or less in height.
- 3 Class 7 Blaster - Blasting Operations and Activities for structures greater than 15 ' in height, bridges, towers, and any of the objects or purposes listed as "Class 5 Blaster or Class 6 Blaster".
- 4 Petroleum Above/Below Ground Storage Tank Removal and Installation (Attach copies of State Certifications.)
- 5 Hazardous Material Removal (Contractor to be certified for asbestos and lead abatement per the Wisconsin Department of Health Services, Asbestos and Lead Section (A&LS).) See the following link for application: www.dhs.wisconsin.gov/Asbestos/Cert. State of Wisconsin Performance of Asbestos Abatement Certificate must be attached.
- 6 Certification number as a Certified Arborist or Certified Tree Worker as administered by the International Society of Arboriculture
- 7 Pesticide application (Certification for Commercial Applicator For Hire with the certification in the category of turf and landscape (3.0) and possess a current license issued by the DATCP)
- 8 State of Wisconsin Master Plumbers License.

SECTION B: PROPOSAL

Please refer to the
Bid Express Website
at <https://bidexpress.com>
look up contract number
and go to
Section B: Proposal Page

You can access all City of Madison bid solicitations for FREE at www.bidexpress.com

Click on the "Register for Free" button and follow the instructions to register your company and yourself. You will be asked for a payment subscription preference, since you may wish to bid online someday. Simply choose the method to pay on a 'per bid' basis. This requires no payment until / unless you actually bid online. You can also choose the monthly subscription plan at this time. You will, however, be asked to provide payment information. Remember, you can change your preference at anytime. You will then be able to complete your free registration and have full access to the site. Your free access does not require completion of the 'Digital ID' process, so you will have instant access for viewing and downloading. To be prepared in case you ever do wish to bid online, you may wish to establish your digital ID also, since you cannot bid without a Digital ID.

If you have any problems with the free registration process, you can call the bidexpress help team, toll free at 1-888-352-2439 (option 1, option1).

SECTION C: SMALL BUSINESS ENTERPRISE

**Instructions to Bidders
City of Madison
SBE Program Information**

SBE NOT APPLICABLE

SECTION D: SPECIAL PROVISIONS

REINDAHL RESTROOM REMODEL CONTRACT NO. 8586

It is the intent of these Special Provisions to set forth the final contractual intent as to the matter involved and shall prevail over the Standard Specifications and plans whenever in conflict therewith. In order that comparisons between the Special Provisions can be readily made, the numbering system for the Special Provisions is equivalent to that of the Specifications.

Whenever in these Specifications the term "Standard Specifications" appears, it shall be taken to refer to the City of Madison Standard Specifications for Public Works Construction and Supplements thereto.

SECTION 102.9 BIDDERS UNDERSTANDING

All Contractors are reminded that this is a Public Works contract for the City of Madison and is exempt from State Sales Tax. Refer to this section of the City Standard Specification for Public Works and Specification 00 62 76.13 in Exhibit B for more information.

SECTION 102.11: BEST VALUE CONTRACTING

This Contract shall be considered a Best Value Contract if the Contractor's bid is equal to or greater than \$70,000 for a single trade contract; or equal to or greater than \$341,500 for a multi-trade contract pursuant to MGO 33.07(7).

SECTION 103: AWARD AND EXECUTION OF THE CONTRACT

The awarded Contractor shall completely execute the signing of all contract documents and submit them to City Engineering (Attn: Alane Boutelle, 1600 Emil Street, Madison, WI 53703) prior to **12:00pm on Thursday, August 04, 2022**. Delays by the Contractor in submitting the required completed contract documents will not adjust the project completion date.

Payment and Performance Bonds shall be dated no sooner than **Wednesday, August 03, 2022**.

SECTION 104: SCOPE OF WORK

This contract is for the remodel of the existing portion of the concessions room of the existing Reindahl Park Splash Pad pump room/concessions building, located at 1818 Portage Rd in Madison, Wis. to create two single use restrooms and a small mechanical room. The scope of work as detailed in the plans and specifications shall include but not limited to demolition of the existing concrete floor, removal of the grease pit, rework of the existing exterior CMU to create new openings and infill of existing openings, new interior concrete floor and CMU. Mechanical, electrical and plumbing systems and fixtures shall be reworked and/or new as shown on the plans and specifications.

The scope of work includes the furnishing of all labor, materials, equipment, tools, and other services necessary to complete the work in accordance with the intent of this contract. The Contractor shall use properly functioning equipment capable of performing the tasks required. The Contractor shall furnish workers who perform quality work and who are experienced and knowledgeable in the work proposed.

SECTION 104.1: LANDS FOR WORK

Demolition and construction activities shall be limited to the Reindahl Park Splash Pad pump and concession building area. The contractor may use the existing driveway area for parking, material storage and/or dumpster. All use of City Lands for Work shall be reviewed and approved by the City's Project Manager.

No tobacco product use is allowed on the Lands for Work.

SECTION 104.2: INTENT AND COORDINATION OF CONTRACT DOCUMENTS

The contract documents are complimentary of each other and consist of all of the following:

- The City Standard Specifications for Public Works Construction, 2022 Edition
- These Special Provisions
- All Addenda to the bidding documents.
- Any supplemental instructions, details, or specifications issued during the course of the contract.
- EXHIBITS FOR BIDDING PURPOSES:
 - EXHIBIT A – Drawings dated June 18, 2021
 - EXHIBIT B – Specifications dated June 18, 2021
 - EXHIBIT C – Existing building plans (7 shts) for Reindahl Splash Pad dated 01/23/2014

SECTION 104.8 REMOVALS

The Contractor shall provide documentation for all disposals of items removed from this site as part of the demolition. Documentation shall include date, material, weight, quantity, volume, and hauler as well as whether it was recycled, diverted from, or entered into a landfill.

Pursuant to City of Madison General Ordinance 10.185, Recycling and Reuse of Construction and Demolition Debris the contractor shall be responsible for recycling all reasonably clean materials including but not limited to concrete, asphalt, and metals from this project site. Contractor shall include all costs associated with recycling/disposal in his/her bid price and shall retain any monies received through recycling efforts. Contractor shall review additional specification 01 74 19.

SECTION 105.5: INSPECTION OF WORK

The Contractor shall coordinate directly with any and all regulatory agencies having jurisdiction over the licensing, permitting, and inspection of work as described in the construction documents.

All Contractors shall be familiar with Specification 01 45 16 – Field Quality Control Procedures regarding City of Madison policies and procedures for Quality Assurance and Quality Control.

SECTION 105.6: CONTRACTORS RESPONSIBILITY FOR WORK

The Contractor shall not take advantage of any discrepancy in the plans or specifications. This shall include, but not be limited to, apparent errors, omissions, and interpretations involving codes, regulations, and standards.

Any Contractor who identifies such a discrepancy during the bidding process shall notify the City Project Manager of the discrepancy prior to the "Questions and Clarifications Deadline" as noted in Section A of the bid documents.

Any Contractor who identifies such a discrepancy after the bidding process and/or after contract signing shall immediately notify the City Project Manager in writing and request clarification on how to proceed. See Specification 01 26 13 – Request for Information (RFI).

SECTION 105.7: CONTRACT DOCUMENTS

The General Contractor is responsible for reproducing all construction documents necessary to complete the Work at their own cost. This shall include plans, specifications, and addenda for the General Contractor and all Sub-contractors. The Contractor shall keep one copy of all drawings and Specifications on the project site, in good order, available to the Project Designers and all City representatives.

SECTION 105.12: COOPERATION BY THE CONTRACTOR

The Contractor shall review all other specifications within the construction documents for other requirements and coordination of work associated with this contract.

The Contractor shall be responsible for all temporary facilities including heat, toilet facilities, etc. as necessary for this contract. Temporary facilities shall include any fuel or service required to operate or maintain the temporary facility.

Construction operations shall be limited to the hours between 7:00 a.m. and 6:00 p.m. Monday through Friday. A request must be made to the City project manager forty-eight hours in advance for approval of work days or hours other than those stated above.

The Contractor shall secure materials at the end of each work day to deter any potential vandalism and theft. The Contractor shall be responsible for ensuring at the end of each day, that the work site is left clean, orderly, free of construction debris, barricades, etc.

The Contractor shall attend a pre-construction meeting prior to the start of construction.

At the time the existing concrete floor has been removed, the Contractor shall coordinate with the owner, the availability of the area where the splash pad piping runs from the pump room to the east exterior wall of the building, in order for City staff to perform inspection of the splash pad existing piping for any leaks and perform any repairs if needed.

SECTION 105.15 SUBSTANTIAL COMPLETION

The Contractor shall refer to Specification 01 77 00 Closeout Procedures for definitions and procedures related to Substantial Completion.

SECTION 107.2: PROTECTION AND RESTORATION OF PROPERTY

The Contractor shall be responsible for the protection and restoration of all new and existing work, including existing splash pad piping that runs under the floor of the new restroom area. See Specification 01 76 00 – PROTECTING INSTALLED CONSTRUCTION.

SECTION 108.2: PERMITS AND LICENSING

The Contractor shall be required to apply and obtain all permits or licenses that may be required by these contract documents regardless of ordinance, statute, or other regulatory requirement. The City of Madison will pay for all City of Madison required Permits.

The Contractor shall obtain and pay for permits and private utility installation fees for this project unless otherwise provided. These costs will include but may not be limited to: gas service/meter set, electric, telephone, and water service/meter set.

The Contractor shall be responsible for any fines issued due to non-compliance with the project permits.

SECTION 109.7: TIME OF COMPLETION

Work shall only begin after the contract is completely executed and the Start Work letter is received. It is anticipated that the Start Work letter shall be issued on or about September 06, 2022. No work at the site can begin before the Tuesday after Labor Day weekend, when the splash pad is officially closed.

The Contractor shall have reached a level of Substantial Completion/Certificate of Occupancy **NO LATER THAN May 05, 2023**. The Contractor shall notify the City project manager three (3) weeks in advance of the selected on-site start date. The total time for completion of this contract shall be sixty (60) calendar

days from the actual start of work on-site. This shall include all minor punch list items, final inspections and all final copies of contract deliverables being submitted.

The Contractor shall review Specifications 01 29 76 Progress Payment Procedures and 01 77 00 Closeout Procedures and be completely familiar with the progress payment milestones and definitions related to construction closeout and contract closeout.

SECTION 109.9: LIQUIDATED DAMAGES

The fixed, agreed upon, liquidated damages for failure to complete all work within the Contract Time, shall be calculated in accordance with Article 109 of Standard Specifications, per working day.

NON STANDARD BID ITEMS

BID ITEM 90000 – BASE BID

DESCRIPTION: The BASE BID shall include the complete installation of all building components; and turn-in of all deliverables as outlined in the plans and specifications.

METHOD OF MEASUREMENT: The BASE BID shall be measured as Lump Sum of the required construction and installations described in the plans and specifications. Partial Payments shall be requested as indicated in Specifications 01 29 73-Schedule of Values and 01 29 76- Progress Payment Procedures.

BASIS OF PAYMENT: The BASE BID shall be paid at the contract unit price. Partial payments shall be reviewed and authorized as described in the above referenced specifications.

POINTS OF CONTACT

Contractors with questions and concerns regarding the bidding documents shall contact the City Project Manager by e-mail so we may properly log, track, and respond to all issues.

Please reference Reindahl Restroom Remodel #8586 in the email subject line.

The City Project Manager for City Engineering, Facilities Management, for this contract is:

Laura Amundson
City of Madison Engineering Division
PH: 608-243-5892
Email: LAmundson@cityofmadison.com

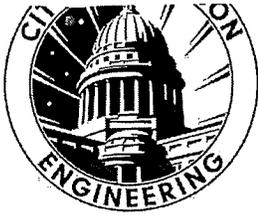

Department of Public Works
Engineering Division
Kathy Cryan, Interim Engineering Manager

City-County Building, Room 115
210 Martin Luther King, Jr. Boulevard
Madison, Wisconsin 53703
Phone: (608) 266-4751
Fax: (608) 264-9275
engineering@cityofmadison.com
www.cityofmadison.com/engineering

Deputy City Engineer
Gregory T. Fries, P.E.

Deputy Division Manager
Kathleen M. Cryan

Principal Architect 2
Bryan Cooper, AIA

Principal Engineer 2
John S. Fahrney, P.E.
Christopher J. Petykowski, P.E.
Janet Schmidt, P.E.

Principal Engineer 1
Christina M. Bachmann, P.E.
Mark D. Moder, P.E.
James M. Wolfe, P.E.

Financial Manager
Steven B. Danner-Rivers

July 01, 2022
ADDENDUM NO. 01
City of Madison, Engineering Division

CONTRACT NO. 8586
REINDAHL RESTROOM REMODEL

This addendum is issued to modify, explain or correct the original Drawings, Specifications, or Contract Documents marked as **REINDAHL RESTROOM REMODEL, City of Madison, Contract #8586, as issued on May 26, 2022** and is hereby made a part of the contract documents.

1. **GENERAL CONTRACT CONDITIONS**

The **bid due date is being extended to Thursday, July 14, 2022 @ 2:00 p.m.** Remove and replace Section A: Advertisement for Bids and Instructions to Bidders (Page A-1).

2. **GENERAL QUESTIONS AND ANSWERS**

1. Contractor sign-in sheet is attached for pre-bid meeting 06/14/2022; No attendees on 06/08/2022.
Q: Can a bulkhead be built in the two restrooms in lieu of raising mechanicals above the bottom of truss line.
A: Yes, it is the Contractor's Option to provide a bulkhead for the mechanicals. Bulkhead size and location to be coordinated onsite and approved by the City Project Manager.

3. **ACCEPTABLE EQUIVALENTS**

No Change

4. **SPECIFICATIONS**

No Change

5. **DRAWINGS**

Exhibit A_Plans_ReindahIRestrooms-FullSet fixed font 11x17.pdf has been uploaded to Bid Express. Sheets A1 and A2 had font corruption and this has been corrected in this Exhibit. No other changes.

6. **PROPOSAL**

No Change

Please acknowledge this addendum on page E1 of the contract documents and/or in Section E: Bidder's Acknowledgement on Bid Express.



Electronic versions of these documents can be found on Bid Express at <https://www.bidexpress.com/> and the City of Madison web site at <http://www.cityofmadison.com/business/PW/contracts/openforBid.cfm>

If you are unable to download plan revisions associated with the addendum, please contact the Engineering office at 608-266-4751 to receive the material by another method.

For questions regarding this bid, contact:

Laura Amundson
City of Madison Engineering
Phone: 608-243-5892
Email: LAmundson@cityofmadison.com

Sincerely,

Christy Bachmann For:
Kathy Cryan, Interim Engineering Manager

SECTION A: ADVERTISEMENT FOR BIDS AND INSTRUCTIONS TO BIDDERS

REQUEST FOR BID FOR PUBLIC WORKS CONSTRUCTION CITY OF MADISON, WISCONSIN

A BEST VALUE CONTRACTING MUNICIPALITY

PROJECT NAME:	REINDAHL RESTROOM REMODEL
CONTRACT NO.:	8586
BID BOND	5%
PRE BID BUILDING TOUR #1 (9:00 A.M.)	JUNE 08, 2022
PRE BID BUILDING TOUR #2 (9:00 A.M.)	JUNE 14, 2022
BIDDER QUESTIONS, CLARIFICATIONS & REQUESTS FOR SBUSTITUTIONS	JUNE 23, 2022
PREQUALIFICATION APPLICATION DUE (2:00 P.M.)	July 07, 2022
BID SUBMISSION (2:00 P.M.)	July 14, 2022
BID OPEN (2:30 P.M.)	July 14, 2022
PUBLISHED IN WSJ	MAY 26, JUN 2, JUN 9, JUN 16, JUN 23 & JUN 30, JUL 7

PRE BID BUILDING TOUR: The City of Madison is conducting two (2) Pre-Bid Walk Building Tour sessions at the existing concessions/pump room building of the Reindahl Park Splash Pad, 1818 Portage Road, Madison, WI, as indicated in the chart above. All contractors are invited to attend a short introductory meeting, a short guided tour of the project area, and then will be allowed to more thoroughly review the project area at their own pace. Please refer to the schedule table above for Building Tour dates and times.

These are the only times contractors shall be allowed access to the interior spaces of the building. Contractors may review exterior public areas at any time during normal business day hours.

City Staff will be in attendance to take questions related to the plans and specifications. Questions shall be recorded and responded to in the form of a published addendum.

BIDDER QUESTIONS, CLARIFICATIONS, AND REQUESTS FOR SUBSTITUTIONS:

If needed, the City Project Manager (CPM) shall publish addenda to respond to any questions, clarifications, or requests for substitutions.

- Any questions or requests for clarifications regarding plans and specifications shall be submitted directly to the CPM. See contact information at the end of Section D – Special Provisions. Responses that change the contract scope and/or schedule will be published by the CPM in the form of a published bidding addendum.
- Requests for substitutions shall be done according to Specification 00 43 25 Substitution Request Form (During Bidding) and other specifications as necessary. Use the form at the end of the specification. Contractors are cautioned to review all specifications and note whether substitutions for specific products will be allowed or not.
- See the contract contact information at the end of Section D-Special Provisions for contact information. All questions and/or substitution requests shall be sent via email with reference to Reindahl Restroom Remodel 8586 in the subject line.
- **The deadline for receiving all questions, clarifications, and requests for substitutions shall be as indicated in the schedule table above.**

PUBLISHING ADDENDUMS:

The City of Madison shall publish bidding addenda as needed during the bidding period. The last addenda (if needed) shall be published on or about 12:00PM, Tuesday, July 05, 2022 to give all contractors sufficient time to review the addenda before bids are due. The City of Madison reminds all



CITY OF MADISON
DEPT OF PUBLIC WORKS
ENGINEERING DIVISION
CITY COUNTY BLDG RM 115
210 MARTIN LUTHER KING JR BLVD
MADISON, WI 53703
PHONE: 608-266-4751

REVISED

play MADISON PARKS

REINDAHL RESTROOM REMODEL

CONTRACT #8586
1818 PORTAGE RD
MADISON, WI 53704
JUNE 18, 2021

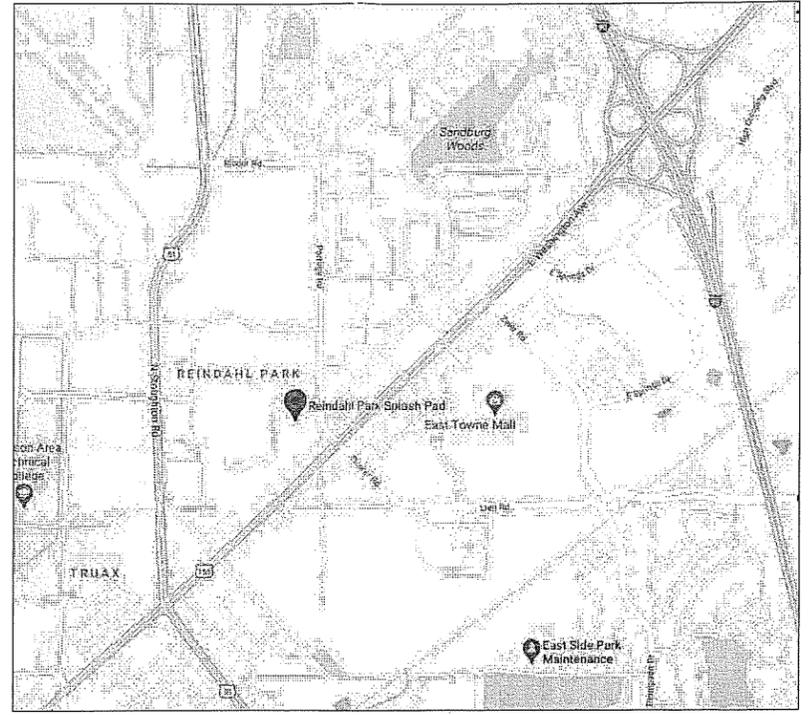
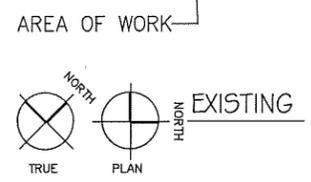
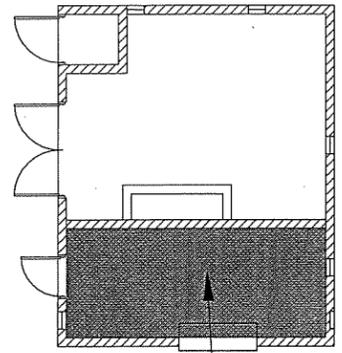

GENERAL NOTES:

1. UNLESS SPECIFICALLY NOTED IN THE PLANS AND SPECIFICATIONS AS WORK OR MATERIALS BY OTHERS, THE CONTRACTOR SHALL ASSUME THE RESPONSIBILITIES OF WORK AND MATERIALS FOR THIS CONTRACT.
2. THE CONTRACTOR SHALL FURNISH ANY APPARATUS, APPLIANCE, MATERIAL, OR LABOR THAT MAY BE NECESSARY TO COMPLETE THE WORK, IN ACCORDANCE WITH THE INTENT OF THIS CONTRACT.
3. THE CONTRACTOR SHALL USE PROPERLY FUNCTIONING EQUIPMENT CAPABLE OF PERFORMING THE TASKS REQUIRED.
4. THE CONTRACTOR SHALL FURNISH WORKERS WHO PERFORM QUALITY WORK AND WHO ARE EXPERIENCED AND KNOWLEDGEABLE IN THE WORK PROPOSED.
5. THE CONTRACTOR SHALL BE RESPONSIBLE FOR THE PROTECTION AND RESTORATION OF ALL NEW AND EXISTING WORK, INCLUDING EXISTING WALKWAYS FROM THE DESIGNATED BUILDING ENTRANCE TO THE CONSTRUCTION AREA, WHICH SHALL REMAIN FREE OF DIRT, MUD, SNOW, SPILLS, SPLATTERS AND PHYSICAL DAMAGE.
6. THE CONTRACTOR SHALL BE RESPONSIBLE FOR KEEPING THE IMMEDIATE AREA AROUND THE PROJECT LIMITS AND ENTRY DOORS CLEAN AND FREE OF CONSTRUCTION MATERIALS AND DEBRIS. THE CONTRACTOR SHALL INSTALL TEMPORARY TARPING AS NEEDED TO KEEP ALL CONSTRUCTION DEBRIS CONFINED TO THE IMMEDIATE PROJECT AREA.
7. THE CONTRACTOR SHALL BE RESPONSIBLE FOR FINAL CLEAN UP OF ALL AREAS AFFECTED BY THIS CONTRACT BEFORE FINAL CONTRACT CLOSEOUT.
8. THE CONTRACTOR SHALL NOT TAKE ADVANTAGE OF ANY DISCREPANCY IN THE PLANS OR SPECIFICATIONS. THIS SHALL INCLUDE BUT NOT BE LIMITED TO APPARENT ERRORS, OMISSIONS, AND INTERPRETATIONS INVOLVING CODES, REGULATIONS, AND STANDARDS.
9. ANY CONTRACTOR WHO IDENTIFIES SUCH A DISCREPANCY DURING THE BIDDING PROCESS SHALL NOTIFY THE CITY PROJECT MANAGER OF THE DISCREPANCY.
10. ANY CONTRACTOR WHO IDENTIFIES SUCH A DISCREPANCY AFTER THE BIDDING PROCESS AND/OR AFTER CONTRACT SIGNING SHALL IMMEDIATELY NOTIFY THE CITY PROJECT MANAGER IN WRITING AND REQUEST CLARIFICATION ON HOW TO PROCEED.
11. ALL DESIGN AND CONSTRUCTION SHALL BE IN ACCORDANCE WITH ALL LOCAL AND STATE OF WISCONSIN BUILDING CODES LATEST EDITION.
12. THE CITY OF MADISON BUILDING PERMIT WILL BE SECURED BY THE OWNER. THE CONTRACTOR SHALL BE REQUIRED TO APPLY FOR AND OBTAIN ALL PERMITS OR LICENSES THAT MAY BE REQUIRED BY THESE CONTRACT DOCUMENTS REGARDLESS OF ORDINANCE, STATUTE, OR OTHER REGULATORY REQUIREMENT.
13. CONTRACTOR IS RESPONSIBLE FOR COORDINATING ALL INSPECTIONS RELATED TO ALL PERMITS AND LICENSES. RE-INSPECTION FEES ASSOCIATED WITH NON-COMPLAINT OR INCOMPLETE WORK SHALL BE THE RESPONSIBILITY OF THE CONTRACTOR.

LANDS FOR WORK:

1. NO TOBACCO PRODUCT USE IS ALLOWED ON THE PROPERTY.
2. WORK SHALL BE PERFORMED BETWEEN THE HOURS OF 7:00 A.M. TO 5:00 P.M.

PUBLIC IMPROVEMENT PROJECT APPROVED: RES - 21-00395 FILE ID 65447 DATE June 07, 2021 BY THE COMMON COUNCIL OF MADISON, WI	PUBLIC IMPROVEMENT DESIGN APPROVED BY: CITY ENGINEER <i>[Signature]</i> DATE May 25, 2022
--	---

SHEET INDEX:

- TS1 TITLE SHEET
- D1 EXISTING AND DEMOLITION PLANS
- A1 RESTROOM FLOOR PLAN & ELEVATIONS
- A2 BUILDING SECTIONS & NOTES
- E1 ELECTRICAL PLAN, SCHEDULE & NOTES
- H1 HVAC PLAN, SCHEDULE & NOTES
- P1 PLUMBING DEMO, NEW PLAN, SCHEDULE, NOTES

REINDAHL RESTROOM REMODEL
1818 PORTAGE RD.
MADISON, WI 53704



MEP STAMP
CONTRACT
#8586
MUNIS
#12789
DRWN BY: LKA
DATE 06/18/21
REV: XX/XX/XX

SHT
T1



CITY OF MADISON
 DEPT. OF PUBLIC WORKS
 ENGINEERING DIVISION
 CITY COUNTY BLDG. RM 115
 210 MARTIN LUTHER KING JR. BLVD
 MADISON, WI 53703
 PHONE: 608-266-4751

REINDAHL RESTROOM REMODEL
 1818 PORTAGE RD.
 MADISON, WI 53704

CONTRACT
 #8586
 MUNIS
 #12789
 DRWN BY: LKA
 DATE 06/18/21
 REV: XX/XX/XX

SHT
 D1

REVISED

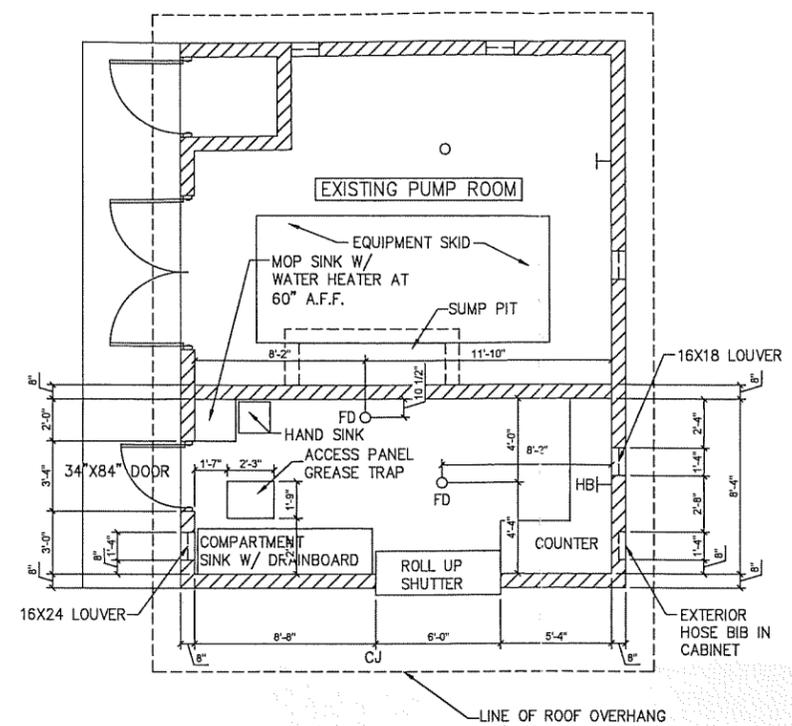

NORTH
 EXISTING CONCESSION ROOM
 SCALE: 1/4" = 1'-0"

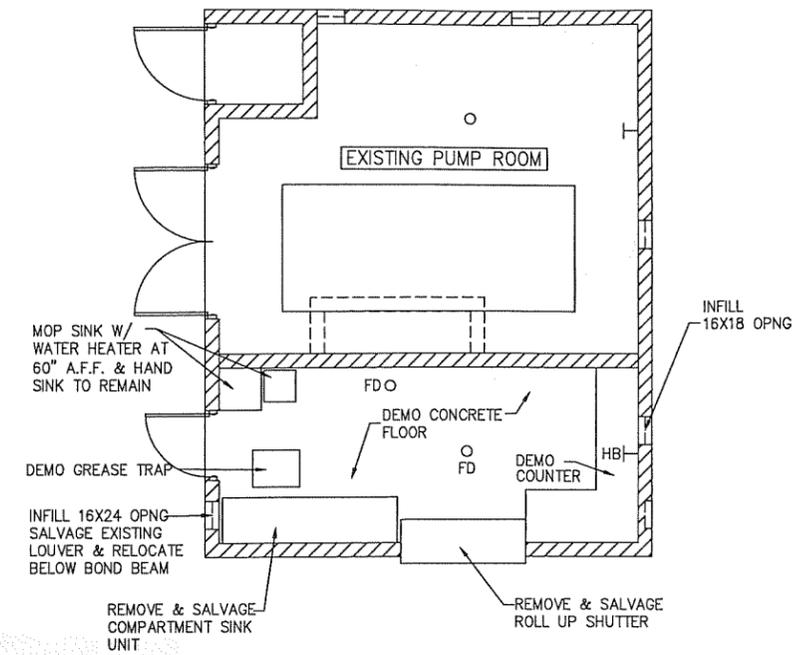

NORTH
 DEMO PLAN
 SCALE: 1/4" = 1'-0"
 SEE SHEET P1 FOR ADDITIONAL PLUMBING DEMO

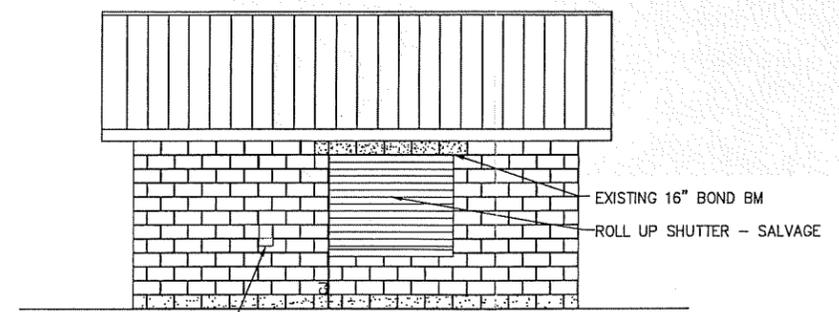

EXISTING EMERGENCY POOL
 PHONE - 911 ONLY CELLULAR
 PHONE INSIDE AC
 BOX WATERPROOF-RELOCATED

EXISTING EAST ELEVATION
 SCALE: 1/4" = 1'-0"



CITY OF MADISON
DEPT OF PUBLIC WORKS
ENGINEERING DIVISION
CITY COUNTY BLDG RM 115
210 MARTIN LUTHER KING JR BLVD
MADISON, WI 53703
PHONE: 608-266-4751

REINDAHL RESTROOM REMODEL
1818 PORTAGE RD.
MADISON, WI 53704

CONTRACT
#8586
MUNIS
#12789
DRWN BY: LKA
DATE 06/18/21
REV: XX/XX/XX

SHT
A1

REVISED

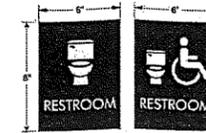

RESTROOM SIGNAGE

1. ACRYLIC MATTE FINISH
2. LETTERS TO BE WHITE 3/4" ARIAL FONT
3. GRAPHIC TO BE +/- 5" TALL
4. BRAILLE UNDER LETTERS TO COMPLY WITH ADA REGULATIONS
5. COLOR: DARK BROWN
6. FASTEN TO CMU USING NON-REMOVABLE STAINLESS STEEL FASTENERS THROUGH PREDRILLED HOLES

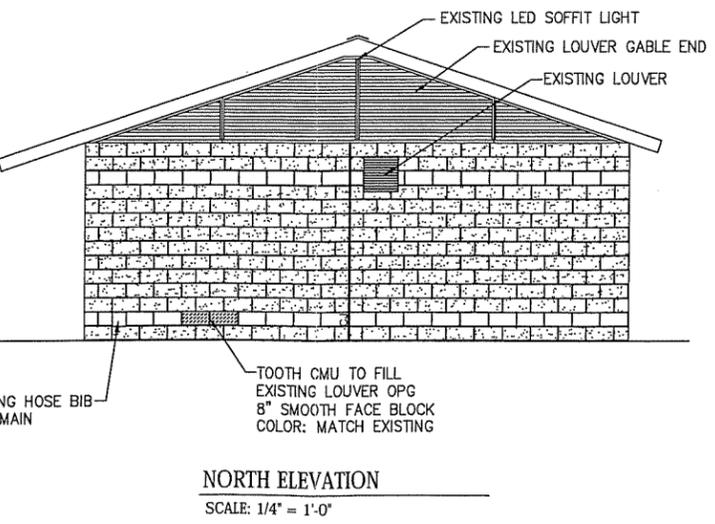
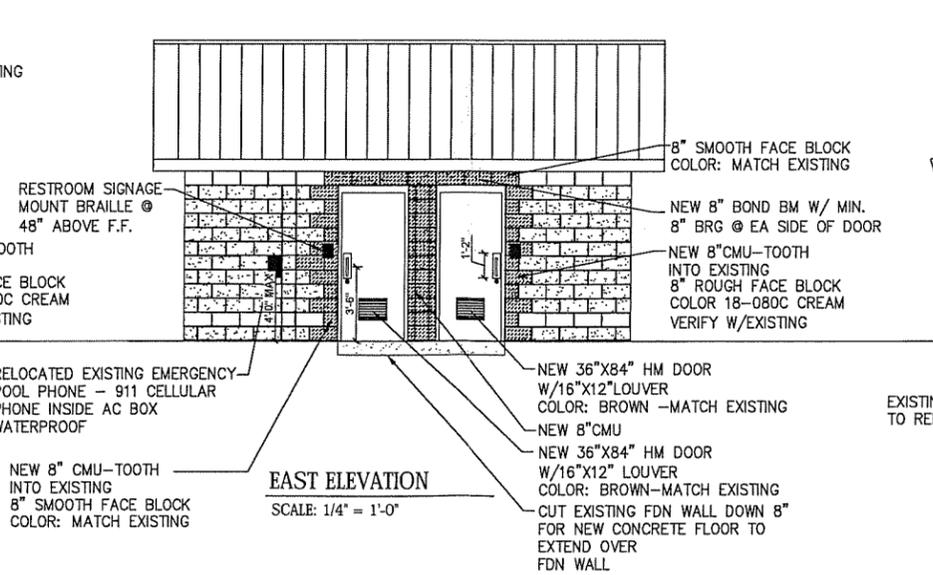
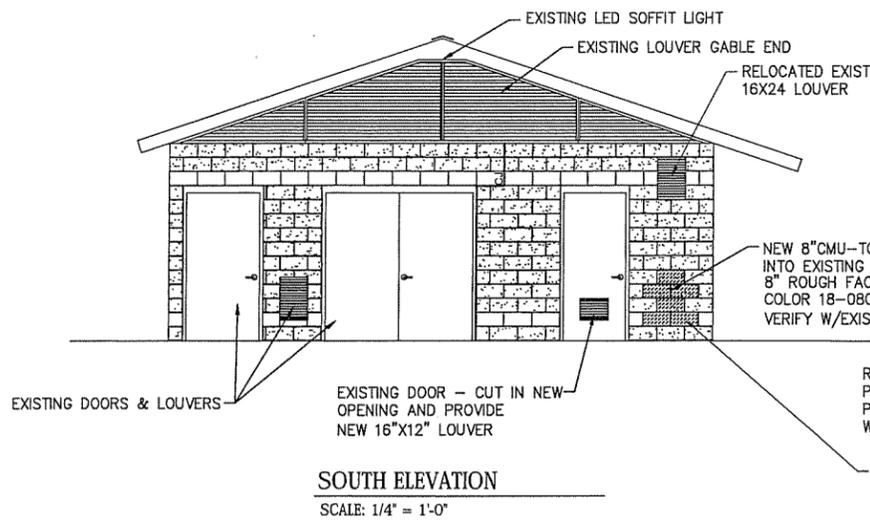
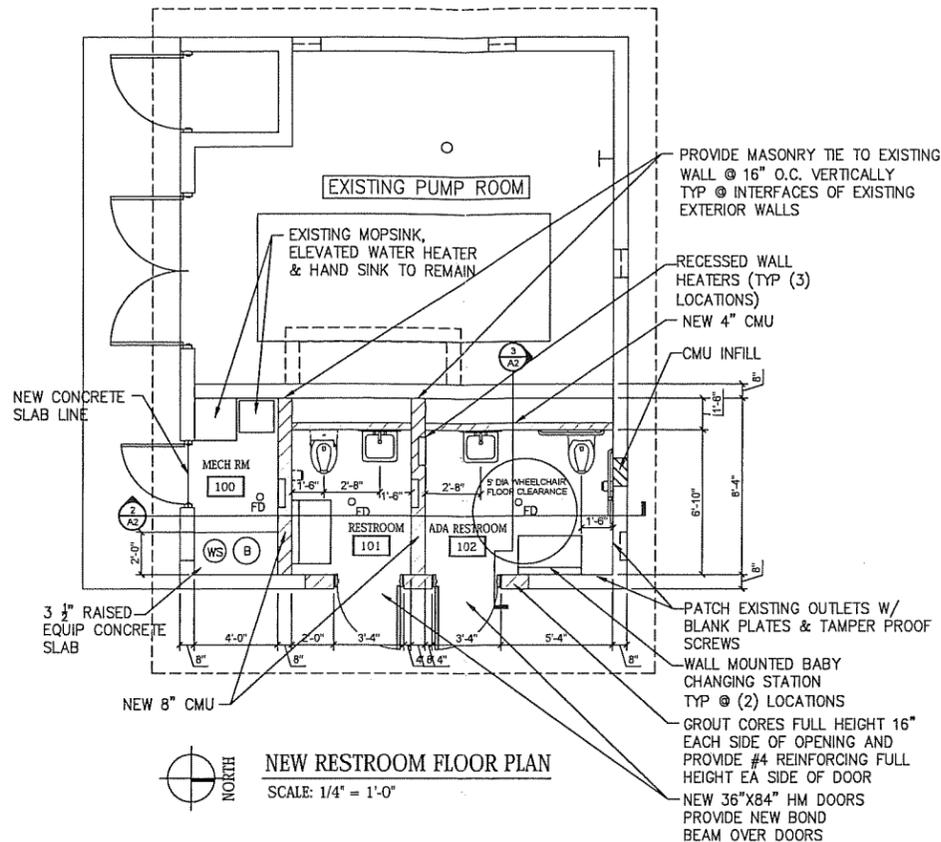



CITY OF MADISON
DEPT. OF PUBLIC WORKS
ENGINEERING DIVISION
CITY COUNTY BLDG. RM. 115
210 MARTIN LUTHER KING JR. BLVD
MADISON, WI 53703
PHONE: 608-260-4751

REINDAHL RESTROOM REMODEL
1818 PORTAGE RD.
MADISON, WI 53704

CONTRACT
#8586
MUNIS
#12789
DRWN BY: LKA
DATE 06/18/21
REV: XX/XX/XX

SHT

A2

REVISED

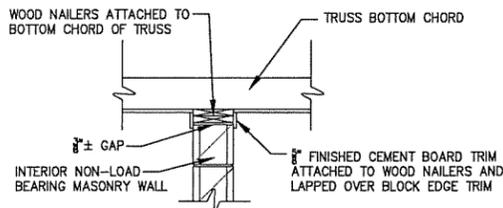
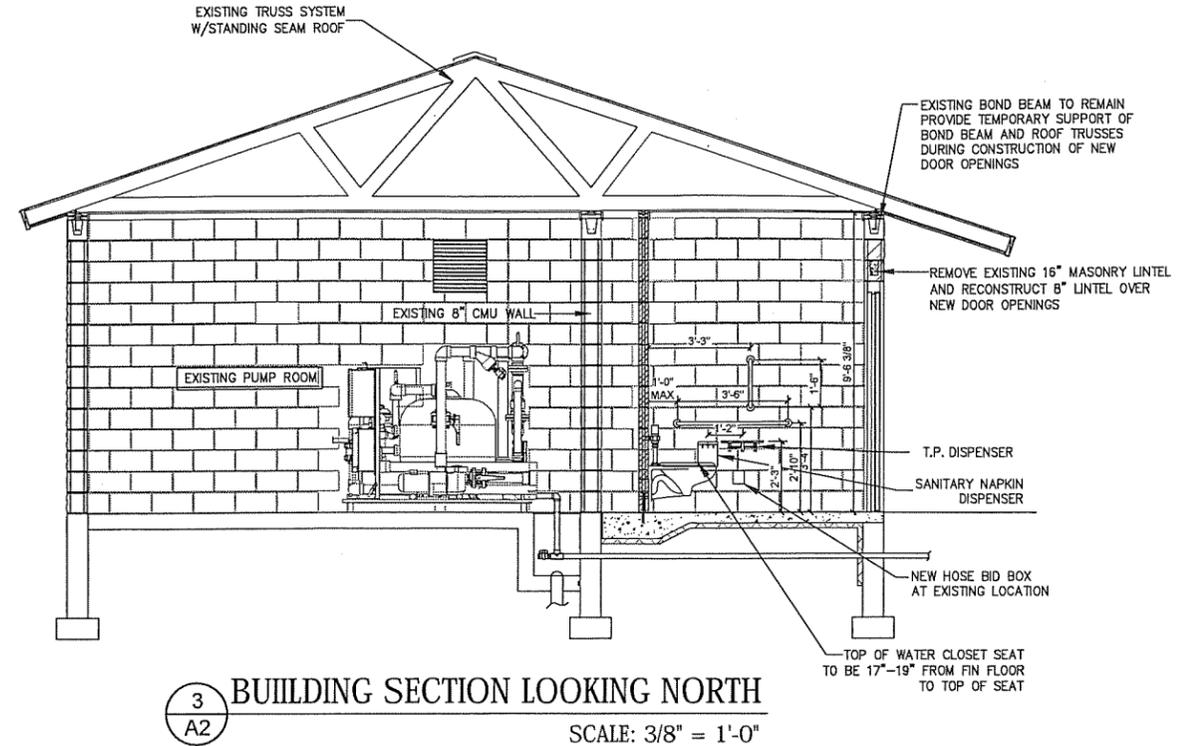
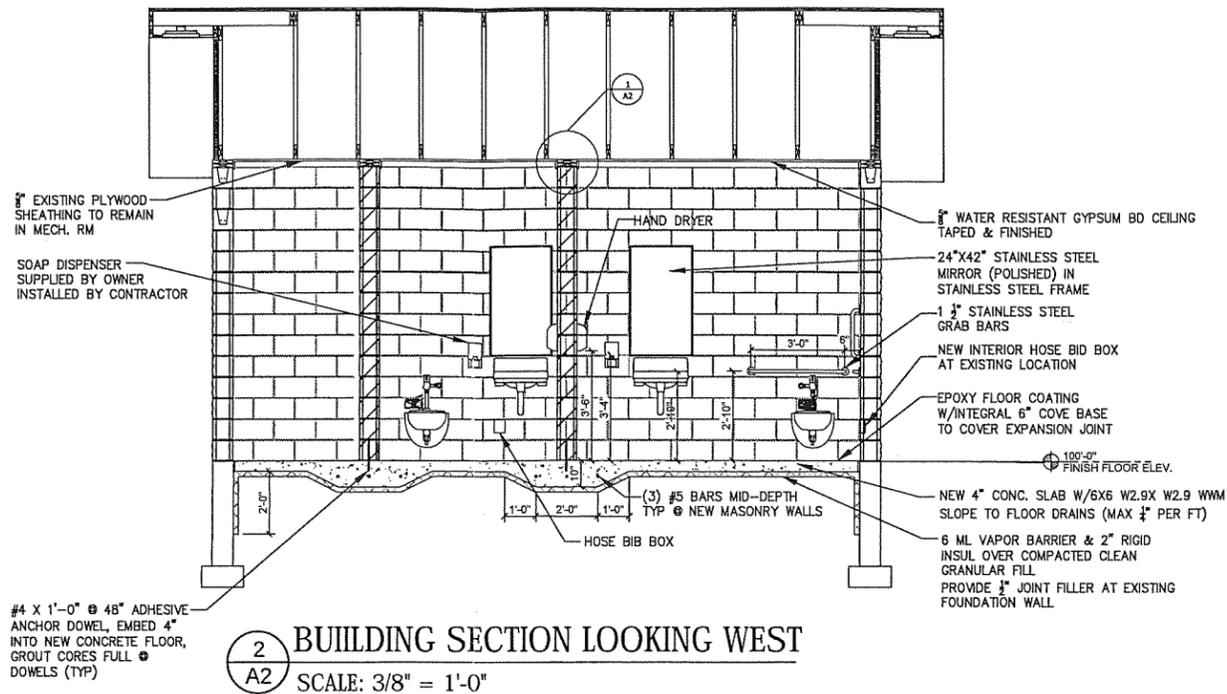

CONCRETE

1. CONCRETE SHALL CONFORM WITH ARTICLE 301 OF THE CITY OF MADISON STANDARD SPECIFICATIONS FOR PUBLIC WORKS CONSTRUCTION.
2. LAP WELDED WIRE MESH 6"; LAP STEEL BARS 18";
3. SLAB FINISH TO BE TROWELED.
4. PROPER CURING PROCEDURES SHALL BE USED FOR SLAB ON GRADE TO PREVENT CURLING.
5. CALCIUM CHLORIDE SHALL NOT BE USED IN CONCRETE MIXES.

CONCRETE MASONRY

1. CONCRETE BLOCK SHALL CONFORM TO THE REQUIREMENTS OF ASTM C90 AND SHALL MATCH THE EXISTING BLOCK COLOR AND TEXTURE. CONCRETE BLOCK OVER DOOR OPENINGS SHALL BE CONSTRUCTED OF LINTEL BLOCK FILLED WITH GROUT.
2. MORTAR SHALL BE TYPE S PORTLAND CEMENT-LIME MORTAR OR MASONRY CEMENT MORTAR WITH PROPORTION RESTRICTIONS AS STATED IN THE WISCONSIN COMMERCIAL BUILDING CODE. PROVIDE INTEGRAL WATERPROOFING COMPOUND IN MORTAR FOR ALL EXTERIOR MASONRY MORTAR.
3. PORTLAND CEMENT SHALL CONFORM TO ASTM C150, TYPE I OR II. HYDRATED LIME SHALL CONFORM TO ASTM C207, TYPE S. MASONRY CEMENT SHALL CONFORM TO ASTM C91 INTEGRAL WATERPROOFING COMPOUND SHALL BE DRY-BLOCK BY W.R. GRACE CO OR EQUAL
4. MORTAR COLOR SHALL BE SELECTED TO MATCH EXISTING MORTAR JOINTS. CONTRACTOR SHALL PROVIDE TEST SAMPLE TO CONFIRM COLOR MATCH FOR MORTAR PRIOR TO BEGINNING WORK.
5. GROUT SHALL CONFORM TO ASTM C476- "MORTAR AND GROUT FOR REINFORCED MASONRY." GROUT SHALL HAVE A MINIMUM 28-DAY COMPRESSIVE STRENGTH OF 2500 PSI
6. WALL REINFORCEMENT SHALL BE 220 LADDER-MESH MANUFACTURED BY HOHMANN & BARNARD, INC., LADDER WIRE, MANUFACTURED BY WIRE-BOND, OR EQUAL. WALL REINFORCEMENT SHALL BE HOT-DIP GALVANIZED WITH A MINIMUM 1.50 OUNCE/SQUARE FOOT ZINC COATING IN ACCORDANCE WITH ASTM A153 CLASS B. PREFABRICATED CORNER AND TEE SECTIONS SHALL BE USED TO PROVIDE CONTINUOUS REINFORCEMENT AROUND CORNERS. INSTALL JOINT REINFORCEMENT IN THE FIRST TWO MORTAR JOINTS AND AT 16-INCH VERTICAL SPACING ABOVE THE SECOND JOINT. LAP 6 INCHES MIN AT SPLICES.
7. ALL MASONRY SHALL BE LAID PLUMB AND TRUE TO LINES. MORTAR BEDS SHALL BE SPREAD SMOOTH OR SLIGHTLY FURROWED. WHERE CUTTING OF EXPOSED MASONRY IS NECESSARY, THE CUTS SHALL BE MADE STRAIGHT AND TRUE.
8. MORTAR JOINTS SHALL BE 3/8" INCH THICK AND SHALL BE COMPLETELY FILLED. JOINTS SHALL BE TOOLED TO MATCH EXISTING MORTAR JOINTS.
9. BED THE ANCHORS OF METAL DOOR FRAMES IN ADJACENT MORTAR JOINTS. GROUT STEEL DOOR FRAMES FULL.
10. WHERE NEW MASONRY JOINTS EXISTING OR PARTIALLY SET MASONRY, THE EXPOSED SURFACE OF EXISTING MASONRY SHALL BE CLEANED AND LIGHTLY WETTED TO OBTAIN THE BEST POSSIBLE BOND WITH THE NEW MASONRY. ALL LOOSE MORTAR SHALL BE REMOVED. MASONRY FACES THAT WILL REMAIN EXPOSED SHALL BE WIPED WITH A DAMP CLOTH AS THE WORK PROGRESSES AND THOROUGHLY CLEANED AND POINTED UPON COMPLETION.

DOOR/DOOR HARDWARE

1. HOLLOW METAL DOORS: BASIS OF DESIGN: CURRIES SERIES 707 16 GA W/POLYSTYRENE CORE. STEEL TOP & BTM FILLER CAPS; FACTORY PRIMED, FINISH TO MATCH EXISTING; W/ 16"X12" LOUVER PRE-FINISHED TO MATCH DOOR
2. HOLLOW METAL FRAMES: BASIS OF DESIGN: CURRIES; 16 GA GALVANIZED CONTINUOUS WELD FACE SEAM, GRIND & FINISH SMOOTH; SILENCERS (3) ON STRIKE JAMB; FACTORY PRIMED, FINISH TO MATCH EXISTING
3. MOUNT HARDWARE IN LOCATIONS RECOMMENDED BY THE DOOR AND HARDWARE INSTITUTE UNLESS OTHERWISE INDICATED.
4. EXIT DEVICE /PUSH PAD: VON DUPRIN 98/99
5. ELECTRIC STRIKE BODY: VON DUPRIN COMPATIBLE W/ EXIT DEVICE; 24 VOLT TRANSFORMER AND ALL NECESSARY CONDUIT AND WIRING BACK TO TIME CLOCK CONTROL PANEL IN MECHANICAL ROOM FOR COMPLETE SYSTEM.
6. DEADLOCKS: CYLINDERS W/ 6 PIN TUMBLER; KEY LOCKS TO OWNER'S MASTER KEY SYSTEM
7. PULL PLATES: BASIS OF DESIGN: IVES; STAINLESS STEEL PULL PLATE 8302 W/ 8102 STAINLESS STEEL PULL 10" CENTERS
8. KICK PLATE: BASIS OF DESIGN: IVES; STAINLESS STEEL 8400 SERIES 10" HIGH ON PUSH SIDE
9. CLOSER: BASIS OF DESIGN: LCN MODEL 4040XP W/ CUSH-N-STOP FEATURE; MOUNT ON PUSH SIDE OF DOOR (PARALLEL ARM MOUNT) FINISH: PAINTED ALUMINUM; ADJUSTABLE DELAYED OPENING (ACCESSIBLE TO PEOPLE W/ DISABILITIES) FEATURE.
10. SADDLE THRESHOLD: BASIS OF DESIGN: REESE #212555 STAINLESS STEEL 1/2"X5" PROFILE
11. DOOR SWEEP: BASIS OF DESIGN: REESE #701 C CLEAR ANODIZED ALUMINUM W/POLYURETHANE
12. WEATHER-STRIP: BASIS OF DESIGN: REESE 775 C CLEAR ANODIZED ALUMINUM W/ POLYURETHANE INSERT
13. WALL STOPS
14. HINGES - (3) BALL BEARING HINGES; STAINLESS STEEL W/ STAINLESS STEEL NON-REMOVABLE HINGE PINS;

ROOM FINISHES

1. FLOOR IN RESTROOMS TO BE 100% EPOXY FLOORING SYSTEM, MEDIUM TO HEAVY DUTY, MIN 1/2" BASE OVERALL THICKNESS W/ INTEGRAL 6" COVE BASE. SLIP RESISTANT, AGGREGATE FILLED. STRICTLY COMPLY WITH MANUFACTURER'S REQUIREMENTS FOR TESTING OF MOISTURE CONTENT. APPROVED MANUFACTURER: DUR-A-FLEX ACCELERA-HQ; COLOR TBD WARRANTY: 3 YEARS FROM DATE OF INSTALL
2. SEALED CONCRETE FLOOR IN MECHANICAL ROOM
3. NEW CMU WALL IN MECHANICAL ROOM TO BE SEALED
4. RESTROOM CMU WALLS TO BE PAINTED: SHERWIN-WILLIAMS WATER BASED TILE CLAD EPOXY; COLOR: ROYCROFT #6072 VERSATILE GRAY; (2) COATS OVER LATEX BLOCK FILLER
5. RESTROOM GYPSUM BOARD CEILINGS TO BE PAINTED: SHERWIN-WILLIAMS WATER BASED EPOXY; COLOR: SNOWBOUND #7004 (2) COATS OVER PRIMER
6. MECHANICAL ROOM CEILING TO REMAIN EXISTING 5/8" PLYWOOD
7. PAINT ATTIC STOCK: PROVIDE ONE UNOPENED GALLON OF EACH COLOR

RESTROOM ACCESSORIES

1. ADA ONLY: GRAB BARS: 1 1/2" OUTSIDE DIAMETER 1.3MM STAINLESS STEEL FOR HEAVY DUTY APPLICATIONS. CONCEALED MOUNTING; SMOOTH SATIN FINISH GRIPPING SURFACE;
2. TOILET TISSUE DISPENSER: ROYCE ROLLS RINGER CO. MODEL #STP-2; DOUBLE ROLL DISPENSER W/ PADDLE LOCK FEATURE; 18 GA STAINLESS STEEL; CONCEALED MOUNTING; LOCK BY OWNER
3. SANITARY NAPKIN DISPOSAL UNIT: ROYCE ROLLS RINGER CO. MODEL #SNR; STAINLESS STEEL #4 FINISH (SATIN); SELF CLOSING COVER;
4. MIRROR: BRADLEY BRIGHT ANNEALED 20 GA STAINLESS STEEL SET IN TAMPER PROOF STAINLESS STEEL FRAME W/ CONCEALED MOUNTING - 24"X42"
5. LIQUID SOAP DISPENSER: SUPPLIED BY OWNER, INSTALLED BY CONTRACTOR
6. WARM-AIR DRYER: EXCEL MODEL HO-1W; SURFACE MOUNTED; ELECTRONIC SENSOR ACTIVATED; STEEL W/ WHITE EPOXY FINISH;
7. BABY CHANGING STATION: BASIS OF DESIGN: KOALA KARE KB200-05; COLOR: WHITE GRANITE #05; WALL MOUNTED W/GAS SPRING MECHANISM; MOUNT WITH HANDLE NO HIGHER THAN 48" ABOVE F.F. AND THE WORK SURFACE LOCATED 28" TO 33" ABOVE F.F.

EXHAUST FAN SCHEDULE	
TAG	EF-1
MANUFACTURER	GREENHECK
MODEL NO.	SQ-90-VG
AREA SERVED	TOILETS & MECH
CFM	300
ESP *WG	1/2"
RPM	1537
MOUNTING	SPRING VIB. HANGERS
DRIVE	DIRECT
SONES (INLET/RADIATED)	7.3/4.2
ELECTRICAL:	
MOTOR HP (BHP)	1/10
FAN F.L.A.	2.2
VOLTAGE/PHASE	115/1
CONTROL	OCCUPIED BLDG MODE
REMARKS:	INLINE EF ①②③④⑤⑦
NOTE:	ALL EF LINE VOLTAGE CONTROLS WIRING BY E.C.
①	INTERLOCK EF-1 WITH TIMECLOCK OCCUPIED MODE SCHEDULE.
②	ECM MOTOR WITH UNIT-MOUNTED POTENTIOMETER FOR BALANCING.
③	SPRING/NEOPRENE VIBRATION ISOLATION HANGERS.
④	MOTORIZED (115V) OPPOSED BLADE, LOW-LEAKAGE DAMPER.
⑤	DIRECT-COUPLED EXTERNAL ACTUATOR (BELIMO).
⑥	NEMA 1 DISCONNECT SWITCH UNIT-MOUNTED.
⑦	INSULATED HOUSING.

DIFFUSERS, REGISTERS AND GRILLES SCHEDULE								
TAG	MFR	MODEL	SIZE	FACE (L)	MOUNTING	SERVICE	CFM	REMARKS
E1	KEES	GHD40	8"x6"	-	SURFACE/WALL	EXHAUST	100	①②③ HD ER 40 deg BL
REMARKS:								ER = EXHAUST REGISTER
① WHITE FINISH.								HD = HEAVY DUTY
② OPPOSED BLADE DAMPER.								
③ SUB-FRAME 24 GA.								

ELECTRIC HEAT SCHEDULE								
TAG	MEGR	MODEL NO.	TYPE	SIZE	WATTS	CAP.	ELECTRICAL	REMARKS
				Ht x W x DEPTH		BTU/HR	VOLTS/PHASE AMPES	
EH-1	Q-MARK	AWH-4404	RECESSED WALL HTR	18" x 15" x 3"	2000	6,825	240/1	8.3 ①②③
① INTEGRAL TAMPER PROOF THERMOSTAT.								
② BUILT-IN DISCONNECT SWITCH.								
③ LKXSPC: 14 GA SECURITY FRONT COVER.								

HVAC GENERAL NOTES:

- HVAC CONTRACTOR IS RESPONSIBLE FOR COORDINATION OF HVAC WORK WITH OTHER TRADES.
- COORDINATE PROVISIONS FOR OPENINGS IN NEW CONSTRUCTION WITH THE GENERAL CONTRACTOR FOR APPROVAL PRIOR TO STARTING WORK.
- HVAC CONTRACTOR IS RESPONSIBLE FOR CUTTING AND PATCHING WALLS, FLOORS & CEILINGS FOR NEW HVAC WORK, IF REQUIRED.
- COORDINATE FINAL CEILING REGISTER AND GRILLE LOCATIONS WITH OTHER TRADES.
- COORDINATE PIPING AND DUCTWORK ROUTING WITH OTHER TRADES TO MAINTAIN SCHEDULED CEILING HEIGHTS.
- PROVIDE PROPER SERVICE CLEARANCES AND ACCESS SPACE FOR ALL NEW EQUIPMENT.
- PROVIDE ACCESS PANELS TO SERVICE EQUIPMENT, WHERE REQUIRED.

HVAC PLAN NOTES:

- ◇ COORDINATE RECESS OPENINGS IN BLOCK WALLS FOR ELECTRIC WALL HEATERS WITH GENERAL CONTRACTOR & MASONRY CONTRACTOR.

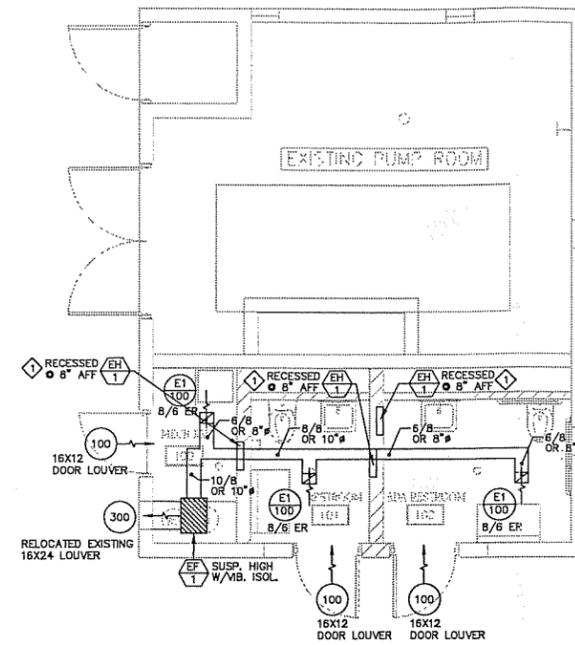

BASE PLAN - HVAC
SCALE: 1/4" = 1'-0"

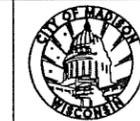

CITY OF MADISON
DEPT OF PUBLIC WORKS
ENGINEERING DIVISION
CITY COUNTY BLDG RM 115
210 MARTIN LUTHER KING JR BLVD
MADISON, WI 53703
PHONE: 608-265-4751

REINDAHL RESTROOM REMODEL
1818 PORTAGE RD.
MADISON, WI 53704

CONTRACT #8586
MUNIS #12789
DRWN BY: LKA
DATE 06/18/21
REV: XX/XX/XX

SHT
H1

REVISD



CITY OF MADISON
DEPT OF PUBLIC WORKS
ENGINEERING DIVISION
CITY COUNTY BLDG RM 115
100 EAST WASHINGTON
MADISON, WI 53703
PHONE: 608-266-4751

REINDAHL RESTROOM REMODEL
1818 PORTAGE RD.
MADISON, WI 53704

CONTRACT #8586
MUNIS #12789
DRWN BY: LKA
DATE 06/18/21
REV: XX/XX/XX

SHT E1

REVISED

ELECTRICAL SYMBOL SCHEDULE

MOUNTING HGT.	SYMBOL	DESCRIPTION
LIGHTING FIXTURES		
	— —	LED LINEAR: SURFACE, CEILING MOUNTED
	— —	LED LINEAR: SURFACE, WALL MOUNTED
SWITCHES		
	\$OS	OCCUPANCY SENSOR CONTROLLED WALL SWITCH
	\$P	SINGLEPOLE - PILOT ILLUMINATED
	⊙	OCCUPANCY SENSOR
	⊙	CEILING MTD TYPE
RECEPTACLES		
	⊞	DUPLEX: SURFACE MTD
	⊞	DUPLEX: W/GROUND FAULT INTERRUPTION PROTECTION
EQUIPMENT AND WIRING		
	⊕	DIRECT EQUIPMENT CONNECTION
	⊕	JUNCTION BOX-CONCEALED IN FINISHED AREAS, SURFACE IN UNFINISHED AREAS
	⊞	TRANSFORMER
EQUIPMENT		
	EH	ELECT. HEATER
	EHD	ELECT. HAND DRYER
ABBREVIATIONS		
	GFI	GROUND FAULT INTERRUPTER
	TC	TIMECLOCK CONTROLLED

ELECTRICAL GENERAL NOTES:

- COORDINATE LIGHTING & DEVICE LAYOUT WITH GENERAL CONTRACTOR.
- COORDINATE ELECTRICAL RACEWAYS ROUTING WITH GENERAL CONTRACTOR AND OTHER TRADES FOR PROPER EQUIPMENT ACCESS.
- ALL RACEWAYS ARE TO BE CONCEALED IN FINISHED AREAS. MECHANICAL & UTILITY AREAS MAY USE SURFACE CONDUIT SYSTEMS.
- ELECTRICAL CONTRACTOR IS RESPONSIBLE FOR FIELD VERIFYING ALL CONSTRUCTION CONDITIONS.
- COORDINATE AND SCHEDULE ALL WORK WITH THE GENERAL CONTRACTOR AND LOW-VOLTAGE CABLING PRIOR TO STARTING.
- ALL LIGHTS CIRCUITED TO EXISTING ELECTRICAL PANEL IN THE PUMP ROOM

ELECTRICAL POWER/LV PLAN NOTES:

- CORNER-MTD LIGHT FIXTURE ● CEILING.
- COORDINATE LIGHT FIXTURE MOUNTING LOCATION WITH DUCTWORK, PIPING & OTHER TRADES.
- COORDINATE POWER TO LOW-VOLTAGE TRANSFORMER FOR FLUSH VALVES BY PLUMBING TRADE. PROVIDE MASTER PILOT LIGHT SWITCH FOR POWER TO FLUSH VALVES AND LABEL. ROUTE ALL LV CABLING IN RACEWAY.
- PROVIDE 4"x4"x2 1/2" RECESSED BOX WITH PLASTER RING FOR SENSOR MOUNTING HEIGHT TO CENTER OF BOX. COORDINATE INSTALLATION WITH PLUMBING TRADE. COORDINATE FINAL MOUNTING HEIGHT LOCATION WITH GENERAL CONTRACTOR.
- PROVIDE 4"x4"x2 1/2" RECESSED BOX WITH PLASTER RING FOR ELECTRIC HAND DRYER CONNECTION. PROVIDE POWER CONNECTION TO HAND DRYERS. COORDINATE FINAL MOUNTING HEIGHT LOCATION WITH GENERAL CONTRACTOR.
- COORDINATE FINAL RECEPTACLE LOCATION WITH PLUMBING TRADE FOR FAUCET SENSOR POWER.
- COORDINATE POWER WIRING AND RACEWAY REQUIREMENTS FOR ELECTRIC HEATERS WITH HVAC CONTRACTOR.
- EXTEND LOW-VOLTAGE CABLING FROM TRANSFORMER (BY P.C.) TO FLUSH VALVE SENSORS. ROUTE CABLING IN CONDUIT OR RACEWAYS.
- DOOR ACCESS TRANSFORMER (120 VAC/24 VDC) AND ELECTRIC STRIKE PROVIDED BY GENERAL CONTRACTOR AND WIRED BY ELECTRICAL TRADE. CONTROL XFMR POWER BY TIME CLOCK. ALL CABLING IN EMT RACEWAY SYSTEM.
- ELECTRICAL CONTRACTOR TO TRACE AND UPDATE CIRCUIT LABELING FOR ALL CIRCUITS IN MAIN ELECTRICAL PANEL. ALL NEW OR MODIFIED OUTLETS AND CIRCUITS TO BE PROPERLY LABELED.
- TIME CLOCK SHALL BE INTERMATIC MODEL ET1725C; EXHAUST FAN AND OCC SENSORS SHALL BE OCCUPIED MODE SCHEDULE; ELECTRIC STRIKE AUTO LOCK SHALL BE UNOCCUPIED MODE SCHEDULE; SET PER OWNER'S REQUESTED OCCUPIED/UNOCCUPIED SCHEDULES.

LIGHTING FIXTURE SCHEDULE

TAG	LAMPS		DESCRIPTION	MOUNTING	MFR. & MODEL	REMARKS
	NO.	WATTS				
A	LED	45	W/FIXTURE	SURFACE/ CORNER MTD	KENALL - MLH45-48-R-MW- PP-1-45L40K-DCC-1-120-CMB	(1)(2) 4 FT VR CORNER MTD SURFACE WRAP
B	LED	42	W/FIXTURE	SURFACE PENDANT/CLG	LITHONIA - ZL2N-L48-3000LM- MDD-MVOLT-40K-BCRI-WH + HC36	(1)(3) 4 FT SURFACE PENDANT CHAIN HUNG STRIP

LAMP ABBREVIATIONS:
LED=LIGHT EMITTING DIODE

REMARKS:
① LED LAMPING/DRIVER.
② CORNER MTG BRACKET (CMB).
③ CHAIN HUNG FIXTURE.
ALL VOLTAGES ARE 120 VOLT UNLESS INDICATED OTHERWISE.

OCCUPANCY SENSOR SCHEDULE

SYMBOL	MOUNTING	VOLTAGE	RATED CURRENT /LOAD	SENSOR		MFR. & MODEL	REMARKS
				TYPE	COVERAGE		
⊙	SURFACE/ CLG	120 VAC	800 Watt	DT	360° 24"x24"	SENSOR SWITCH RMR-PDT-B-LT	(1)(2) RECESSED CLG MTD DT
\$OS	WALL SWITCH	120 VAC	800 Watt	DT	180° 20"	SENSOR SWITCH WSD-PDT	(1) WALL SWITCH DT

ABBREVIATIONS:
PIR-PASSIVE INFRARED
U=ULTRASONIC
DT=DUAL TECHNOLOGY (PIR+U)
(1) COORDINATE PLATE FINISH COLOR WITH ARCHITECT. (2) LOW-TEMPERATURE RATED

PANEL BOARD SCHEDULE

AMPS MAIN		VOLTS PHASE		MOUNTING LOCATION	
400 120/240		120/240 1		SURFACE EXISTING PUMP ROOM	
BRKR	DESCRIPTION	CIRCUIT	CIRCUIT	DESCRIPTION	BRKR
A P					A P
20 1	EXISTING EXTERIOR OUTLETS	1	2	EXISTING ELEC WTR HTR MECH 100	20 2
20 1	EXISTING INTERIOR LIGHTS	3	4	EXISTING ELEC WTR HTR MECH 100	20 -
20 1	EXTERIOR BUILDING LIGHTS	5	6	EXISTING TIMECLOCK	20 1
50 2	EXISTING WATER QUALITY SYSTEM	7	8	NEW TIMECLOCK	20 1
50 -	EXISTING WATER QUALITY SYSTEM	9	10	NEW DOOR ACCESS XFMR	20 1
20 1	EXISTING OUTLETS - PUMP RM	11	12	NEW EF-1	15 1
20 1	EXISTING OUTLETS - PUMP RM	13	14	EXISTING PF1 (EXH FAN PUMP RM)	20 1
20 1	EXISTING OUTLETS - PUMP RM	15	16	EXISTING PF1 (EXH FAN CHEM RM)	20 1
15 1	EXISTING SOLENOID VALVE(SHOWER)	17	18	EXISTING SPLASH PAD PUMP	70 2
20 1	EXISTING EMERGENCY PHONE	19	20	EXISTING SPLASH PAD PUMP	70 -
20 1	NEW EHD RM 101	21	22	NEW RECEPT FLUSH VALVES-LAV	15 1
20 1	NEW EHD RM 102	23	24	NEW XFMR - FLUSH VALVES	15 1
		25	26	NEW INTERIOR LIGHTS	20 1
		27	28	NEW OUTLETS MECH 101	20 1
		29	30		20 1
25 2	NEW EH-1 MECH RM 100	31	32		
-	NEW EH-1 MECH RM 100	33	34		
25 2	NEW EH-1 RESTROOM 101	35	36		20 1
-	NEW EH-1 RESTROOM 101	37	38		20 1
25 2	NEW EH-1 ADA RESTROOM 102	39	40		20 1
-	NEW EH-1 ADA RESTROOM 102	41	42		20 1

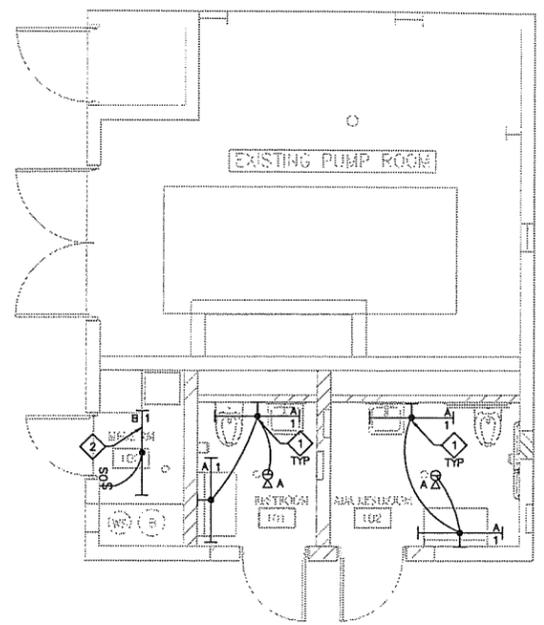

ELECTRICAL - LIGHTING
SCALE: 1/4" = 1'-0"

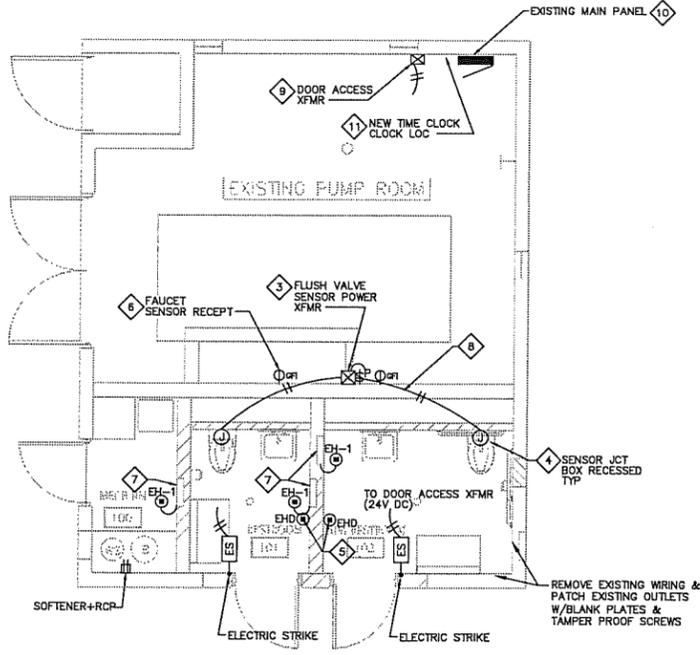

ELECTRICAL - POWER
SCALE: 1/4" = 1'-0"



CITY OF MADISON
DEPT. OF PUBLIC WORKS
ENGINEERING DIVISION
CITY COUNTY BLDG. RM. 115
210 MARTIN LUTHER KING JR. BLVD.
MADISON, WI 53703
PHONE: 608-266-4751

REINDAHL RESTROOM REMODEL
1818 PORTAGE RD.
MADISON, WI 53704

CONTRACT #8586
MUNIS #12789
DRWN BY: LKA
DATE 06/18/21
REV: 08/09/21

SHT

P1

REVISED

PLUMBING FIXTURE SCHEDULE

P#	FIXTURE	WASTE	VENT	CW.	HW.	DESCRIPTION
WC-1	WATER CLOSET	4"	1-1/2"	1"	---	VITREOUS CHINA, WHITE, WALL-MTD. ELONGATED BOWL, REAR SPUD, RIM Ø 16" AFF. FIXTURE EQUAL TO KOHLER KINGSTON K-4323, SLOAN OPTIMA 152-1.6 ES-S SENSOR OPERATED FLUSH VALVE (1.6 GPF) & BEMIS 1955-SSC OPEN FRONT SEAT. PROVIDE EL-154 (120V) TRANSFORMER & VERTICAL ADJ. WALL CARRIERS EQUAL TO SMITH 0230 SERIES.
WC-2	WATER CLOSET ADA	4"	1-1/2"	1"	---	SAME AS WC EXCEPT RIM MTD Ø 17" ADA COMPLIANT.
LAV-1	LAVATORY ADA	1-1/4"	1-1/2"	1/2"	1/2"	VITREOUS CHINA, WHITE, WALL HUNG EQUAL TO KOHLER KINGSTON LAV K-1729. (2-HOLE 4" O.C.) W/SLOAN EIT-600-P-BDM ELECTRIC FAUCET, MECH MIXING VALVE, EIT-233 (120V) PLUG-IN TRANSFORMER, MOUNT CONTROL MODULE & TRANSFORMER IN EXISTING PUMP ROOM W/GROMMET OPENING IN WALL. FROWRAP 2000 INSULATION GUARDS, CONCEALED ARM CARRIER EQUAL TO SMITH 0700 SERIES & KOHLER 8999 P-TRAP WITH CLEANOUT, ADA COMPLIANT.
HB-1	HOSE BIBB	---	---	1/2"	---	INTERIOR WALL HOSE BIBB, AUTOMATIC DRAINING WITH ANTI-SIPHON VB. PIPE MOUNTED, EQUAL TO WOODFORD MODEL 24P. (ASSE 1011).
FD-1	FLOOR DRAIN	3"	1-1/2"	---	---	POLISHED BRONZE ADJ. ROUNDTOP W/PROSET TRAP GUARD EQUAL TO SMITH MODEL 2005Y-A-PB (NO HUB), 2010C-A-PB (CAULKED OUTLET).
HD-1	HUB DRAIN	2"	1-1/2"	---	---	STUB UP WASTE HUB RIM OUTLET 4" A.F.F.
WS-1	WATER SOFTENER	OPEN SITE DRAIN	---	1-1/2"	---	CAPITAL SOFTENER WS-15 OR APPROVED EQUAL, CAPACITY = 64,000 GRAIN, 2.0 OF RESIN, 33 GPM @ 15 PSIG MAX WPD. SOFTENER SIZE: 13" x 63"H. BRINE TANK: 18" x 40" H (300 LB. SALT CAP.). 1" VALVE/MANIFOLD, METRED DEMAND-CONTROLLED REGENERATION. PROVIDE BOTTOM DRAIN FOR WINTERIZING.
RCP-1	HW RECIRCULATION PUMP W/TIMELOCK	---	---	---	3/4"	GRUNDFOS UP10-16 BNS/TLC 1.0 GPM @ 4FT W/TIMER & LINER CORD. 115V, 1-PHASE, 1/2 HP, 0.22 AMPS.

PLUMBING GENERAL NOTES:

1. PLUMBING CONTRACTOR IS RESPONSIBLE FOR FIELD VERIFYING ALL EXISTING CONDITIONS.
2. COORDINATE PHASING OF WORK WITH GENERAL CONTRACTOR.
3. ALL PLUMBING PIPING SHALL BE CONCEALED EXCEPT IN MECHANICAL ROOM 100

PLUMBING PLAN NOTES:

1. COORDINATE ROUTING OF PIPING WITH OTHER TRADES FOR PROPER SERVICE CLEARANCES.
2. COORDINATE INSTALLATION OF LAV WALL CARRIER SUPPORTS WITH GENERAL CONTRACTOR & MASONRY TRADE.
3. COORDINATE INSTALLATION OF WC WALL CARRIER SUPPORTS WITH GENERAL CONTRACTOR & MASONRY TRADE.
4. COORDINATE PLACEMENT OF RECESSED/FLUSH SENSOR BOX (4x4) AT EACH FIXTURE WITH GENERAL CONTRACTOR & MASONRY TRADE.
5. COORDINATE SENSOR TRANSFORMER PLACEMENT WITH ELECTRICAL TRADE FOR LINE VOLTAGE POWER. LOW-VOLTAGE POWER BY PLUMBING TRADE IN CONDUIT (EXPOSED) PER DIVISION 16.
6. MOUNT CONTROL MODULE & TRANSFORMER IN EXISTING PUMP ROOM. CABLE CONTROLS THROUGH WALL GROMMET. PROVIDE ADDITIONAL CABLE LENGTHS AS REQUIRED. COORDINATE WORK WITH E.C.
7. SLOPE ALL WATER PIPING TO LOW POINTS WITH DRAIN VALVE FOR WINTERIZING.
8. RECIRCULATE HW WITHIN 2 FT OF LAVATORY ROUGH-IN.

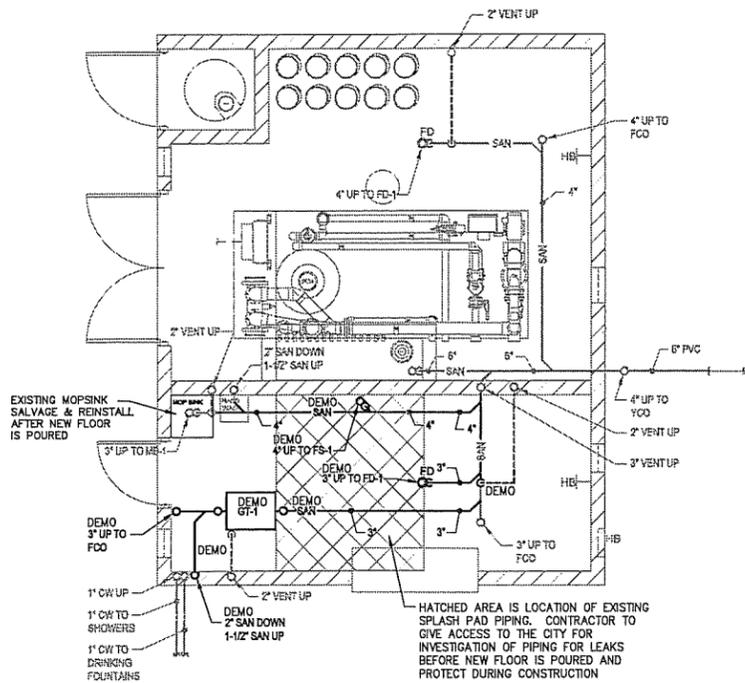

EXISTING PLUMBING BELOW FLOOR & DEMO PLAN

SCALE: 1/4" = 1'-0"

NOTES:

BOLD LINE DENOTES DEMO'D EXISTING ITEMS

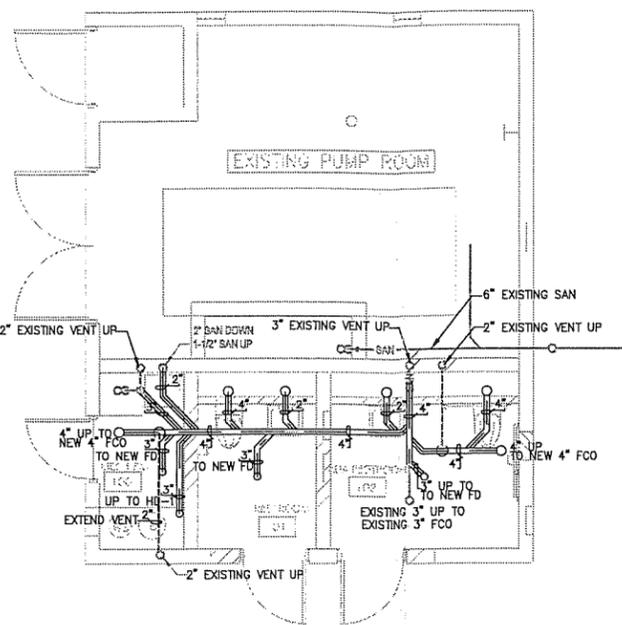

NEW PLUMBING BELOW FLOOR

SCALE: 1/4" = 1'-0"

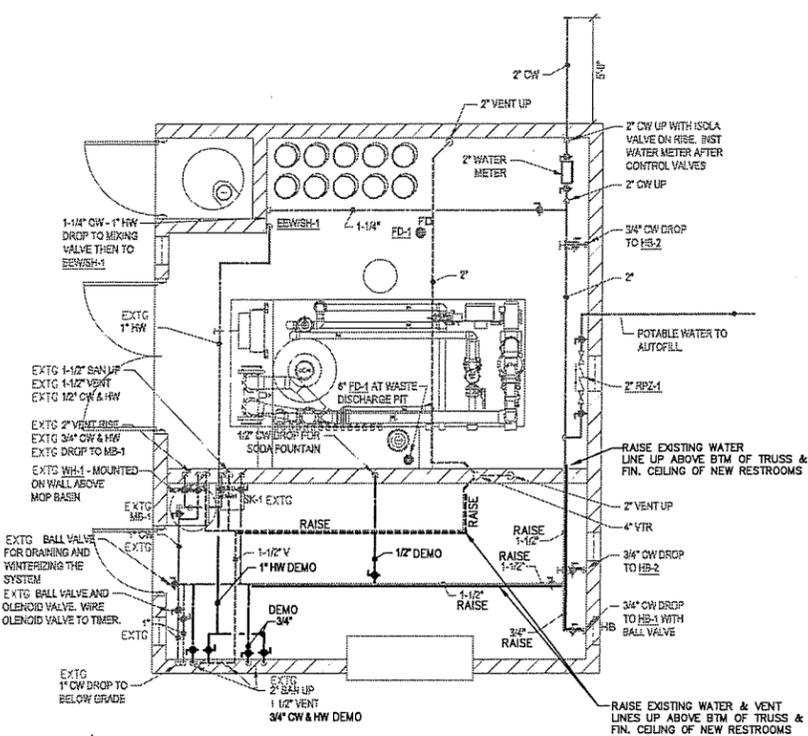

EXISTING PLUMBING ABOVE FLOOR & DEMO PLAN

SCALE: 1/4" = 1'-0"

NOTES:

BOLD LINE DENOTES DEMO'D OR MODIFIED EXISTING ITEMS

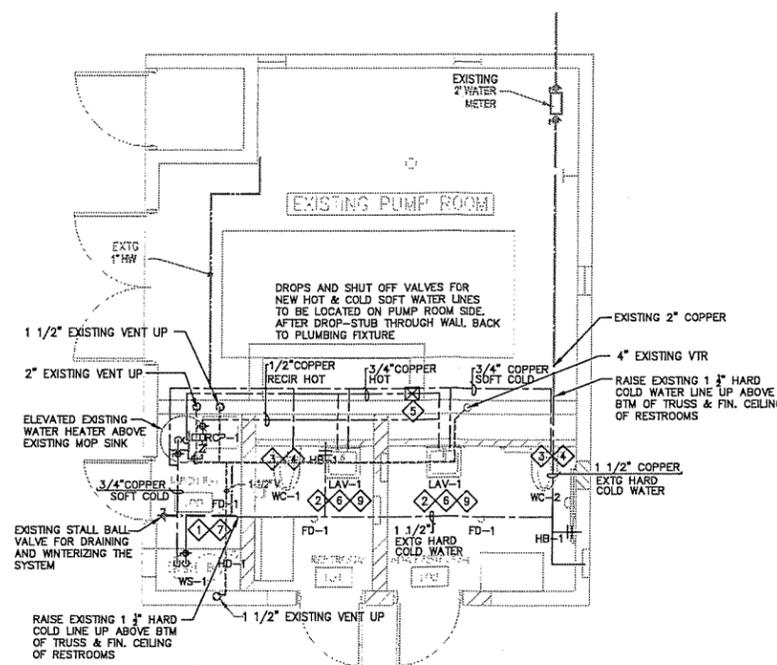

NEW PLUMBING ABOVE FLOOR

SCALE: 1/4" = 1'-0"

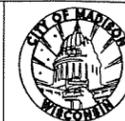

CITY OF MADISON
 DEPT OF PUBLIC WORKS
 ENGINEERING DIVISION
 CITY COUNTY BLDG. RM. 115
 210 MARTIN LUTHER KING, JR. BLVD
 MADISON, WI 53703
 PHONE: 608-266-4751

ORIGINAL

REINDAHL RESTROOM REMODEL
 1818 PORTAGE RD.
 MADISON, WI 53704

CONTRACT #8586
 MUNIS #12789
 DRWN BY: LKA
 DATE 06/18/21
 REV: XX/XX/XX

SHT D1

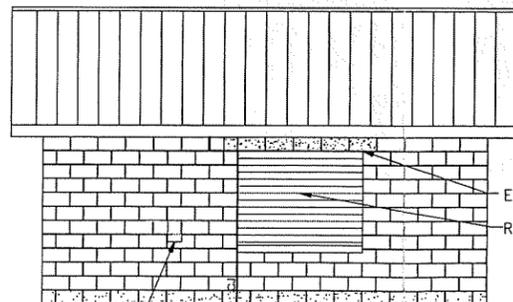
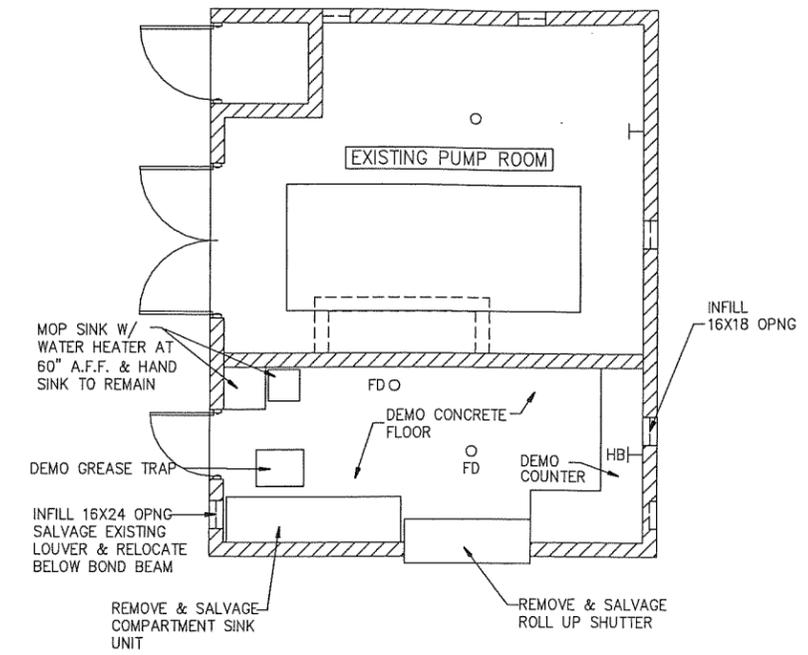
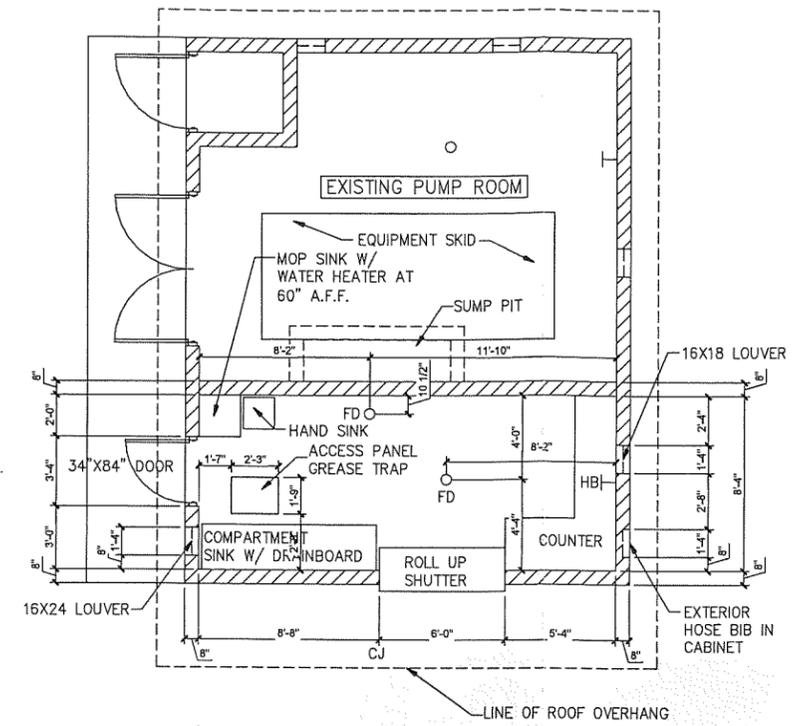

EXISTING EMERGENCY POOL
 PHONE - 911 ONLY CELLULAR
 PHONE INSIDE AC
 BOX WATERPROOF-RELOCATED

ELECTRICAL SYMBOL SCHEDULE

MOUNTING HGT.	SYMBOL	DESCRIPTION
LIGHTING FIXTURES		
		LED LINEAR: SURFACE, CEILING MOUNTED
		LED LINEAR: SURFACE, WALL MOUNTED
SWITCHES		
		OCCUPANCY SENSOR CONTROLLED WALL SWITCH
		SINGLEPOLE - PILOT ILLUMINATED
		OCCUPANCY SENSOR
		CEILING MTD TYPE
RECEPTACLES		
		DUPLEX: SURFACE MTD
		DUPLEX: W/GROUND FAULT INTERRUPTION PROTECTION
EQUIPMENT AND WIRING		
		DIRECT EQUIPMENT CONNECTION
		JUNCTION BOX--CONCEALED IN FINISHED AREAS, SURFACE IN UNFINISHED AREAS
		TRANSFORMER
EQUIPMENT		
		EH = ELECT. HEATER
		EHD = ELECT. HAND DRYER
ABBREVIATIONS		
		GFI=GROUND FAULT INTERRUPTER
		TC=TIMECLOCK CONTROLLED

ELECTRICAL GENERAL NOTES:

- COORDINATE LIGHTING & DEVICE LAYOUT WITH GENERAL CONTRACTOR.
- COORDINATE ELECTRICAL RACEWAYS ROUTING WITH GENERAL CONTRACTOR AND OTHER TRADES FOR PROPER EQUIPMENT ACCESS.
- ALL RACEWAYS ARE TO BE CONCEALED IN FINISHED AREAS. MECHANICAL & UTILITY AREAS MAY USE SURFACE CONDUIT SYSTEMS.
- ELECTRICAL CONTRACTOR IS RESPONSIBLE FOR FIELD VERIFYING ALL CONSTRUCTION CONDITIONS.
- COORDINATE AND SCHEDULE ALL WORK WITH THE GENERAL CONTRACTOR AND LOW-VOLTAGE CABLING PRIOR TO STARTING.
- ALL LIGHTS CIRCUITED TO EXISTING ELECTRICAL PANEL IN THE PUMP ROOM

ELECTRICAL POWER/LV PLAN NOTES:

- CORNER-MTD LIGHT FIXTURE @ CEILING.
- COORDINATE LIGHT FIXTURE MOUNTING LOCATION WITH DUCTWORK, PIPING & OTHER TRADES.
- COORDINATE POWER TO LOW-VOLTAGE TRANSFORMER FOR FLUSH VALVES BY PLUMBING TRADE. PROVIDE MASTER PILOT LIGHT SWITCH FOR POWER TO FLUSH VALVES AND LABEL. ROUTE ALL LV CABLING IN RACEWAY.
- PROVIDE 4"x4"x2 1/2" RECESSED BOX WITH PLASTER RING FOR SENSOR MOUNTING HEIGHT TO CENTER OF BOX. COORDINATE INSTALLATION WITH PLUMBING TRADE. COORDINATE FINAL MOUNTING HEIGHT LOCATION WITH GENERAL CONTRACTOR.
- PROVIDE 4"x4"x2 1/2" RECESSED BOX WITH PLASTER RING FOR ELECTRIC HAND DRYER CONNECTION. PROVIDE POWER CONNECTION TO HAND DRYERS. COORDINATE FINAL MOUNTING HEIGHT LOCATION WITH GENERAL CONTRACTOR.
- COORDINATE FINAL RECEPTACLE LOCATION WITH PLUMBING TRADE FOR FAUCET SENSOR POWER.
- COORDINATE POWER WIRING AND RACEWAY REQUIREMENTS FOR ELECTRIC HEATERS WITH HVAC CONTRACTOR.
- EXTEND LOW-VOLTAGE CABLING FROM TRANSFORMER (BY P.C.) TO FLUSH VALVE SENSORS. ROUTE CABLING IN CONDUIT OR RACEWAYS.
- DOOR ACCESS TRANSFORMER (120 VAC/24 VDC) AND ELECTRIC STRIKE PROVIDED BY GENERAL CONTRACTOR AND WIRED BY ELECTRICAL TRADE. CONTROL XFMR POWER BY TIME CLOCK. ALL CABLING IN EMT RACEWAY SYSTEM.
- ELECTRICAL CONTRACTOR TO TRACE AND UPDATE CIRCUIT LABELING FOR ALL CIRCUITS IN MAIN ELECTRICAL PANEL. ALL NEW OR MODIFIED OUTLETS AND CIRCUITS TO BE PROPERLY LABELED.
- TIME CLOCK SHALL BE INTERMATIC MODEL ET1725C; EXHAUST FAN AND OCC SENSORS SHALL BE OCCUPIED MODE SCHEDULE; ELECTRIC STRIKE AUTO LOCK SHALL BE UNOCCUPIED MODE SCHEDULE; SET PER OWNER'S REQUESTED OCCUPIED/UNOCCUPIED SCHEDULES.

LIGHTING FIXTURE SCHEDULE

TAG	NO.	TYPE	LAMPS	DESCRIPTION	MOUNTING	MFGR. & MODEL	REMARKS
A	-	LED	45	W/FIXTURE	SURFACE/ CORNER MTD	KENALL - MLH45-48-R-MW-PP-1-4SL40K-3CC-1-120-CMB	(1)(2) 4 FT VR CORNER MTD SURFACE WRAP
B	-	LED	42	W/FIXTURE	SURFACE PENDANT/CLG	LITHONIA - ZL2N-L4B-3000LM-MDD-MVOLT-40K-80CRI-WH + HC36	(1)(3) 4 FT SURFACE PENDANT CHAIN HUNG STRIP

LAMP ABBREVIATIONS:
LED=LIGHT EMITTING DIODE

REMARKS:
① LED LAMPING/DRIVER.
② CORNER MTG BRACKET (CMB).
③ CHAIN HUNG FIXTURE.

ALL VOLTAGES ARE 120 VOLT UNLESS INDICATED OTHERWISE.

OCCUPANCY SENSOR SCHEDULE

SYMBOL	MOUNTING	VOLTAGE	RATED CURRENT /LOAD	SENSOR TYPE	COVERGE	MFGR. & MODEL	REMARKS
	SURFACE/ CLG	120 VAC	800 Watt	DT	360+ 24 x24'	SENSOR SWITCH RMR-POT-9-LT	(1)(2) RECESSED CLG MTD DT
	WALL SWITCH	120 VAC	800 Watt	DT	180+ 20'	SENSOR SWITCH WSD-PDT	(1) WALL SWITCH DT

ABBREVIATIONS:
PIR=PASSIVE INFRARED
U=ULTRASONIC
DT=DUAL TECHNOLOGY (PIR+U)

(1) COORDINATE PLATE FINISH COLOR WITH ARCHITECT. (2) LOW-TEMPERATURE RATED

PANEL BOARD SCHEDULE

AMPS MAIN		VOLTS PHASE		MOUNTING LOCATION		
400 120/240		120/240 1		SURFACE EXISTING PUMP ROOM		
BRKR	DESCRIPTION	CIRCUIT		CIRCUIT	DESCRIPTION	BRKR
A P						A P
20 1	EXISTING EXTERIOR OUTLETS	1		2	EXISTING ELEC WTR HTR MECH 100	20 2
20 1	EXISTING INTERIOR LIGHTS	3		4	EXISTING ELEC WTR HTR MECH 100	20 -
20 1	EXTERIOR BUILDING LIGHTS	5		6	EXISTING TIMECLOCK	20 1
50 2	EXISTING WATER QUALITY SYSTEM	7		8	NEW TIMECLOCK	20 1
50 -	EXISTING WATER QUALITY SYSTEM	9		10	NEW DOOR ACCESS XFMR	20 1
20 1	EXISTING OUTLETS - PUMP RM	11		12	NEW EF-1	15 1
20 1	EXISTING OUTLETS - PUMP RM	13		14	EXISTING PF1 (EXH FAN PUMP RM)	20 1
20 1	EXISTING OUTLETS - PUMP RM	15		16	EXISTING PEF1(EXH FAN CHEM RM)	20 1
15 1	EXISTING SOLENOID VALVE(SHOWER)	17		18	EXISTING SPLASH PAD PUMP	70 2
20 1	EXISTING EMERGENCY PHONE	19		20	EXISTING SPLASH PAD PUMP	70 -
20 1	NEW EHD RM 101	21		22	NEW RECEPT FLUSH VALVES-LAV	15 1
20 1	NEW EHD RM 102	23		24	NEW XFMR - FLUSH VALVES	15 1
		25		26	NEW INTERIOR LIGHTS	20 1
		27		28	NEW OUTLETS MECH 101	20 1
		29		30		20 1
25 2	NEW EH-1 MECH RM 100	31		32		
-	NEW EH-1 MECH RM 100	33		34		
25 2	NEW EH-1 RESTROOM 101	35		36		20 1
-	NEW EH-1 RESTROOM 101	37		38		20 1
25 2	NEW EH-1 ADA RESTROOM 102	39		40		20 1
-	NEW EH-1 ADA RESTROOM 102	41		42		20 1

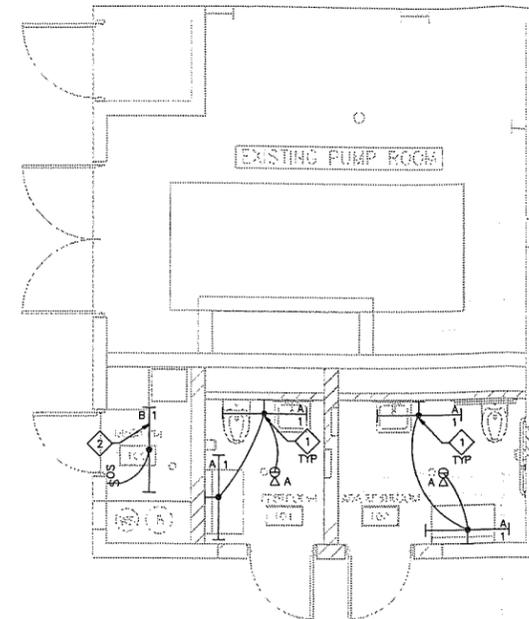

ELECTRICAL - LIGHTING
SCALE: 1/4" = 1'-0"

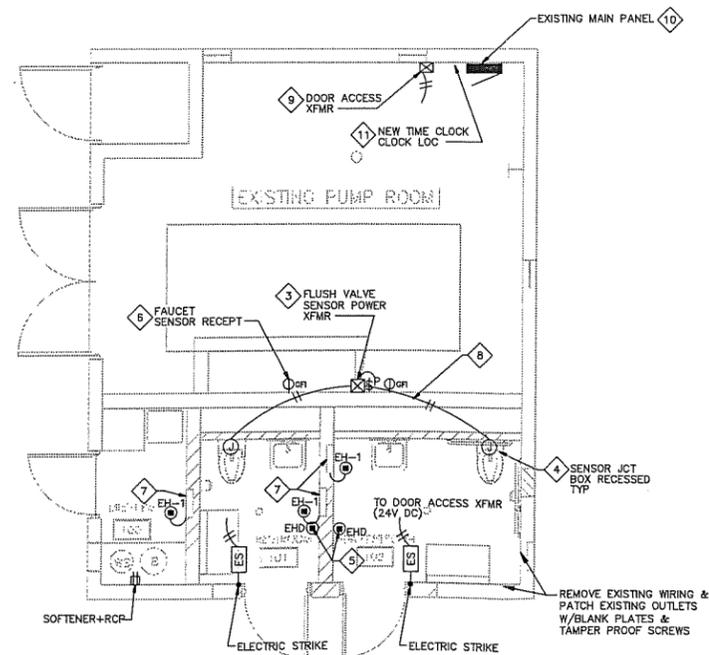

ELECTRICAL - POWER
SCALE: 1/4" = 1'-0"



CITY OF MADISON
DEPT OF PUBLIC WORKS
ENGINEERING DIVISION
CITY COUNTY BLDG RM 115
210 MARTIN LUTHER KING JR BLVD
MADISON, WI 53703
PHONE: 608-266-4751

REINDAHL RESTROOM REMODEL
1818 PORTAGE RD.
MADISON, WI 53704

CONTRACT #8586
MUNIS #12789
DRWN BY: LKA
DATE 06/18/21
REV: XX/XX/XX

SHT E1

ORIGINAL

EXHAUST FAN SCHEDULE	
TAG	EF-1
MANUFACTURER	GREENHECK
MODEL NO.	SQ-90-VG
AREA SERVED	TOILETS & MECH
CFM	300
ESP *WG	1/2"
RPM	1537
MOUNTING	SPRING VIB. HANGERS
DRIVE	DIRECT
SONES (INLET/RADIATED)	7.3/4.2
ELECTRICAL:	
MOTOR HP (BHP)	1/10
FAN F.L.A.	2.2
VOLTAGE/PHASE	115/1
CONTROL	OCCUPIED BLDG MODE
REMARKS:	INLINE EF ①②③④⑤⑥⑦
NOTE: ALL EF LINE VOLTAGE CONTROLS WIRED BY E.C.	
① INTERLOCK EF-1 WITH TIMECLOCK OCCUPIED MODE SCHEDULE.	
② ECM MOTOR WITH UNIT-MOUNTED POTENTIOMETER FOR BALANCING.	
③ SPRING/NEOPRENE VIBRATION ISOLATION HANGERS.	
④ MOTORIZED (115V) OPPOSED BLADE, LOW-LEAKAGE DAMPER.	
⑤ DIRECT-COUPLED EXTERNAL ACTUATOR (BELMO).	
⑥ NEMA 1 DISCONNECT SWITCH UNIT-MOUNTED.	
⑦ INSULATED HOUSING.	

DIFFUSERS, REGISTERS AND GRILLES SCHEDULE							
TAG	MFR	MODEL	SIZE	MOUNTING	SERVICE	CFM	REMARKS
E1	KEES	CHD40	8"x6" NECK (WxH) FACE (L)	SURFACE/WALL	EXHAUST	100	①②③ HD ER 40 deg BL
REMARKS: ① WHITE FINISH. ② OPPOSED BLADE DAMPER. ③ SUB-FRAME 24 GA. ER = EXHAUST REGISTER HD = HEAVY DUTY							

ELECTRIC HEAT SCHEDULE								
TAG	MEGR	MODEL NO.	TYPE	SIZE	WATTS	CAP.	ELECTRICAL	REMARKS
EH-1	Q-MARK	AWH-4404	RECESSED WALL HTR	18?"x15E"x3R"	2000	6,825	240/1	8.3 ①②③
REMARKS: ① INTEGRAL TAMPER PROOF THERMOSTAT. ② BUILT-IN DISCONNECT SWITCH. ③ LFKSFC: 14 GA SECURITY FRONT COVER.								

HVAC GENERAL NOTES:

- HVAC CONTRACTOR IS RESPONSIBLE FOR COORDINATION OF HVAC WORK WITH OTHER TRADES.
- COORDINATE PROVISIONS FOR OPENINGS IN NEW CONSTRUCTION WITH THE GENERAL CONTRACTOR FOR APPROVAL PRIOR TO STARTING WORK.
- HVAC CONTRACTOR IS RESPONSIBLE FOR CUTTING AND PATCHING WALLS, FLOORS & CEILINGS FOR NEW HVAC WORK, IF REQUIRED.
- COORDINATE FINAL CEILING REGISTER AND GRILLE LOCATIONS WITH OTHER TRADES.
- COORDINATE PIPING AND DUCTWORK ROUTING WITH OTHER TRADES TO MAINTAIN SCHEDULED CEILING HEIGHTS.
- PROVIDE PROPER SERVICE CLEARANCES AND ACCESS SPACE FOR ALL NEW EQUIPMENT.
- PROVIDE ACCESS PANELS TO SERVICE EQUIPMENT, WHERE REQUIRED.

HVAC PLAN NOTES:

- COORDINATE RECESS OPENINGS IN BLOCK WALLS FOR ELECTRIC WALL HEATERS WITH GENERAL CONTRACTOR & MASONRY CONTRACTOR.

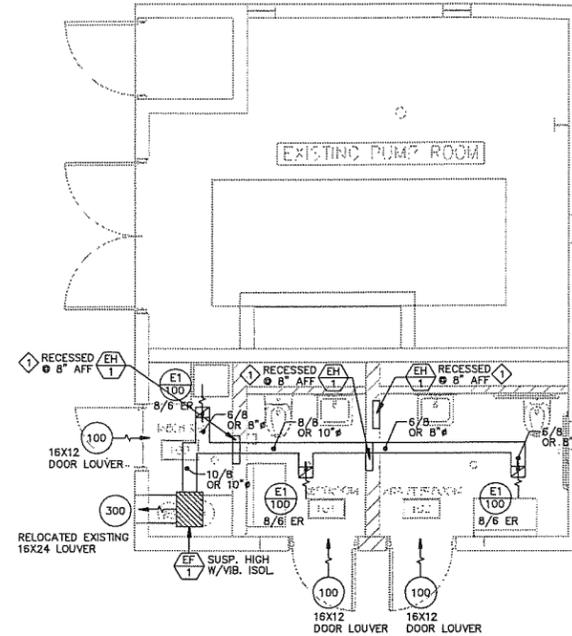

NORTH
BASE PLAN - HVAC
SCALE: 1/4" = 1'-0"



CITY OF MADISON
DEPT OF PUBLIC WORKS
ENGINEERING DIVISION
CITY COUNTY BLDG RM 115
210 MARTIN LUTHER KING JR BLVD
MADISON, WI 53703
PHONE: 608-266-4751

REINDAHL RESTROOM REMODEL
1818 PORTAGE RD.
MADISON, WI 53704

CONTRACT #8586
MUNIS #12789
DRWN BY: LKA
DATE 06/18/21
REV: XX/XX/XX

SHT

H1

ORIGINAL



CITY OF MADISON
DEPT. OF PUBLIC WORKS
ENGINEERING DIVISION
CITY COUNTY BLDG. RM. 115
210 MARTIN LUTHER KING JR. BLVD
MADISON, WI 53703
PHONE: 608-266-4751

REINDAHL RESTROOM REMODEL
1818 PORTAGE RD.
MADISON, WI 53704

CONTRACT #8586
MUNIS #12789
DRWN BY: LKA
DATE 06/18/21
REV: 08/09/21

SHT P1

OREIGNAL

PLUMBING FIXTURE SCHEDULE

P#	FIXTURE	WASTE	VENT	CW.	HW.	DESCRIPTION
WC-1	WATER CLOSET	4"	1-1/2"	1"	---	VITREOUS CHINA, WHITE, WALL-MTD. ELONGATED BOWL, REAR SPUD, RIM Ø 16" AFF. FIXTURE EQUAL TO KOHLER KINGSTON K-4323, SLOAN OPTIMA 152-1.6 ES-S SENSOR OPERATED FLUSH VALVE (1.6 GPF) & BEMIS 1955-SSC OPEN FRONT SEAT. PROVIDE EL-154 (120V) TRANSFORMER & VERTICAL ADJ. WALL CARRIERS EQUAL TO SMITH D230 SERIES.
WC-2	WATER CLOSET ADA	4"	1-1/2"	1"	---	SAME AS WC EXCEPT RIM MTD Ø 17" ADA COMPLIANT.
LAV-1	LAVATORY ADA	1-1/4"	1-1/2"	1/2"	1/2"	VITREOUS CHINA, WHITE, WALL HUNG EQUAL TO KOHLER KINGSTON LAV K-1729, (2-HOLE 4" O.C.) W/SLOAN ETF-600-P-BDM ELECTRIC FAUCET, MECH MIXING VALVE, ETF-233 (120V) PLUG-IN TRANSFORMER, MOUNT CONTROL MODULE & TRANSFORMER IN EXISTING PUMP ROOM W/GROMMET OPENING IN WALL. PRONWRAP 2000 INSULATION GUARDS, CONCEALED ARM CARRIER EQUAL TO SMITH 0700 SERIES & KOHLER B998 P-TRAP WITH CLEANOUT. ADA COMPLIANT.
HB-1	HOSE BIBB	---	---	1/2"	---	INTERIOR WALL HOSE BIBB, AUTOMATIC DRAINING WITH ANTI-SIPHON VB. PIPE MOUNTED. EQUAL TO WOODFORD MODEL 24P. (ASSE 1011).
FD-1	FLOOR DRAIN	3"	1-1/2"	---	---	POLISHED BRONZE ADJ. ROUNDTOP W/PROSET TRAP GUARD EQUAL TO SMITH MODEL 2005Y-A-PB (NO HUB), 2010C-A-PB (CAULKED OUTLET).
HD-1	HUB DRAIN	2"	1-1/2"	---	---	STUB UP WASTE HUB RIM OUTLET 4" A.F.F.
WS-1	WATER SOFTENER	OPEN SITE DRAIN	---	1-1/2"	---	CAPITAL SOFTENER WS-15 OR APPROVED EQUAL CAPACITY = 64,000 GRAIN, 2.0 CF RESIN, 33 GPM @ 15 PSIG MAX WPD, SOFTENER SIZE: 13"x63"H. BRINE TANK: 18" x 40" H (300 LB. SALT CAP.), 1" VALVE/ARMFOLD, METERED DEMAND-CONTROLLED REGENERATION. PROVIDE BOTTOM DRAIN FOR WINTERIZING.
RCP-1	HW RECIRCULATION PUMP W/TIMELOCK	---	---	---	3/4"	GRUNDFOS UP10-16 BNS/TLC 1.0 GPM @ 4FT W/TIMER & BOTTOM CORD. 115V. 1-PHASE, 1/2 HP, 0.22 AMPS.

PLUMBING GENERAL NOTES:

- PLUMBING CONTRACTOR IS RESPONSIBLE FOR FIELD VERIFYING ALL EXISTING CONDITIONS.
- COORDINATE PHASING OF WORK WITH GENERAL CONTRACTOR.
- ALL PLUMBING PIPING SHALL BE CONCEALED EXCEPT IN MECHANICAL ROOM 100

PLUMBING PLAN NOTES:

- COORDINATE ROUTING OF PIPING WITH OTHER TRADES FOR PROPER SERVICE CLEARANCES.
- COORDINATE INSTALLATION OF LAV WALL CARRIER SUPPORTS WITH GENERAL CONTRACTOR & MASONRY TRADE.
- COORDINATE INSTALLATION OF WC WALL CARRIER SUPPORTS WITH GENERAL CONTRACTOR & MASONRY TRADE.
- COORDINATE PLACEMENT OF RECESSED/FLUSH SENSOR BOX (4x4) AT EACH FIXTURE WITH GENERAL CONTRACTOR & MASONRY TRADE.
- COORDINATE SENSOR TRANSFORMER PLACEMENT WITH ELECTRICAL TRADE FOR LINE VOLTAGE POWER. LOW-VOLTAGE POWER BY PLUMBING TRADE IN CONDUIT (EXPOSED) PER DIVISION 16.
- MOUNT CONTROL MODULE & TRANSFORMER IN EXISTING PUMP ROOM. CABLE CONTROLS THROUGH WALL GROMMET. PROVIDE ADDITIONAL CABLE LENGTHS AS REQUIRED. COORDINATE WORK WITH E.C.
- SLOPE ALL WATER PIPING TO LOW POINTS WITH DRAIN VALVE FOR WINTERIZING.
- RECIRCULATE HW WITHIN 2 FT OF LAVATORY ROUGH-IN.

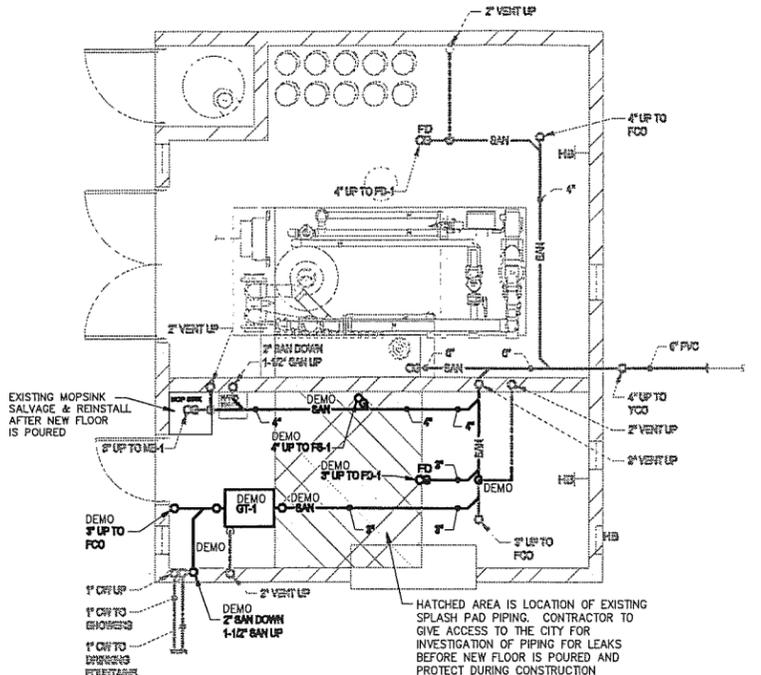

EXISTING PLUMBING BELOW FLOOR & DEMO PLAN

SCALE: 1/4" = 1'-0"

NOTES:

BOLD LINE DENOTES DEMO'D EXISTING ITEMS

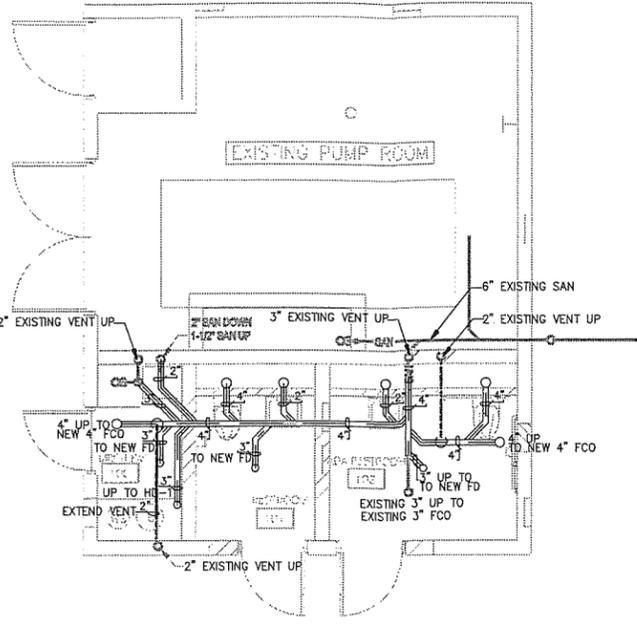

NEW PLUMBING BELOW FLOOR

SCALE: 1/4" = 1'-0"

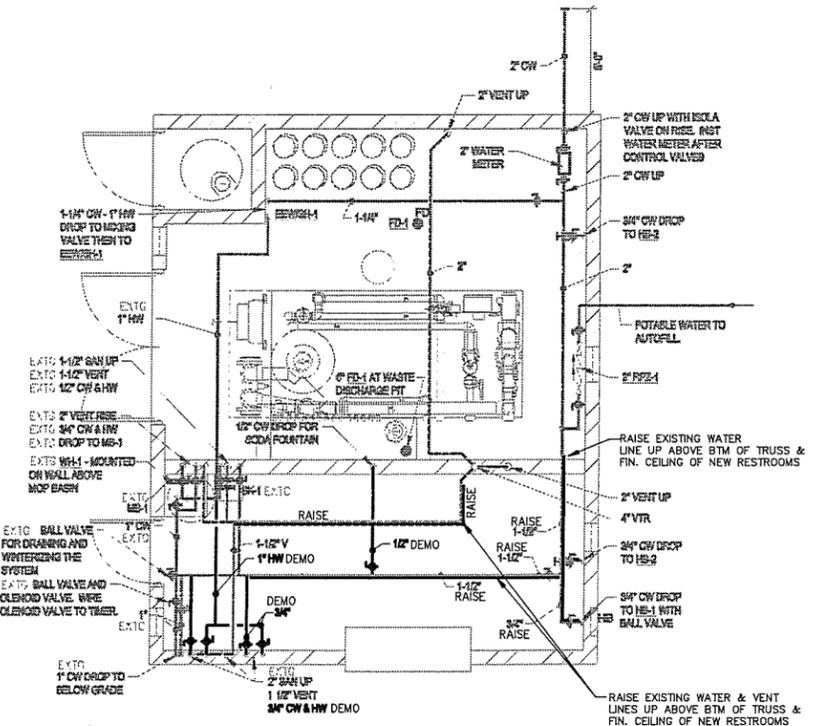

EXISTING PLUMBING ABOVE FLOOR & DEMO PLAN

SCALE: 1/4" = 1'-0"

NOTES:

BOLD LINE DENOTES DEMO'D OR MODIFIED EXISTING ITEMS

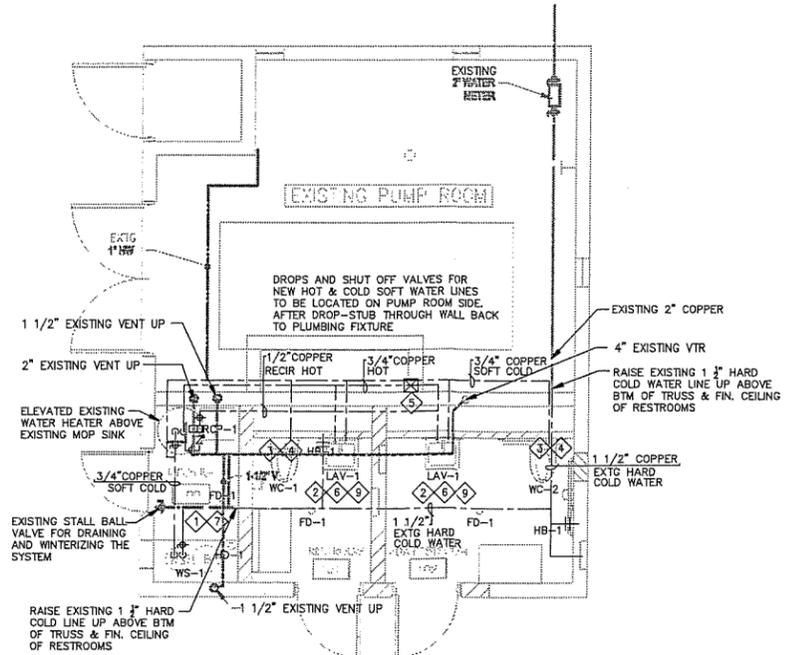

NEW PLUMBING ABOVE FLOOR

SCALE: 1/4" = 1'-0"

SECTION E: BIDDERS ACKNOWLEDGEMENT

CONTRACT TITLE REINDAHL RESTROOM REMODEL

CONTRACT NO. 8586

Bidder must state a Unit Price and Total Bid for each item. The Total Bid for each item must be the product of quantity, by Unit Price. The Grand Total must be the sum of the Total Bids for the various items. In case of multiplication errors or addition errors, the Grand Total with corrected multiplication and/or addition shall determine the Grand Total bid for each contract. The Unit Price and Total Bid must be entered numerically in the spaces provided. All words and numbers shall be written in ink.

- The undersigned having familiarized himself/herself with the Contract documents, including Advertisement for Bids, Instructions to Bidders, Form of Proposal, City of Madison Standard Specifications for Public Works Construction - 2022 Edition thereto, Form of Agreement, Form of Bond, and Addenda issued and attached to the plans and specifications on file in the office of the City Engineer, hereby proposes to provide and furnish all the labor, materials, tools, and expendable equipment necessary to perform and complete in a workmanlike manner the specified construction on this project for the City of Madison; all in accordance with the plans and specifications as prepared by the City Engineer, including Addenda to the Contract Nos. 1 through 1 issued thereto, at the prices for said work as contained in this proposal. (Electronic bids submittals shall acknowledge addendum under Section E and shall not acknowledge here)
- If awarded the Contract, we will initiate action within seven (7) days after notification or in accordance with the date specified in the contract to begin work and will proceed with diligence to bring the project to full completion within the number of work days allowed in the Contract or by the calendar date stated in the Contract.
- The undersigned Bidder or Contractor certifies that he/she is not a party to any contract, combination in form of trust or otherwise, or conspiracy in restraint of trade or commerce or any other violation of the anti-trust laws of the State of Wisconsin or of the United States, with respect to this bid or contract or otherwise.
- I hereby certify that I have met the Bid Bond Requirements as specified in Section 102.5. (IF BID BOND IS USED, IT SHALL BE SUBMITTED ON THE FORMS PROVIDED BY THE CITY. FAILURE TO DO SO MAY RESULT IN REJECTION OF THE BID).
- I hereby certify that all statements herein are made on behalf of BACHMANN CONSTRUCTION COMPANY, INC. (name of corporation, partnership, or person submitting bid) a corporation organized and existing under the laws of the State of WISCONSIN a partnership consisting of _____; an individual trading as _____; of the City of _____ State of _____; that I have examined and carefully prepared this Proposal, from the plans and specifications and have checked the same in detail before submitting this Proposal; that I have fully authority to make such statements and submit this Proposal in (its, their) behalf; and that the said statements are true and correct.

SIGNATURE

Project Manager
TITLE, IF ANY

Sworn and subscribed to before me this 14th day of JULY, 2022

Patricia A. Raetz
(Notary Public or other officer authorized to administer oaths)

My Commission Expires July 21, 2024

Bidders shall not add any conditions or qualifying statements to this Proposal.

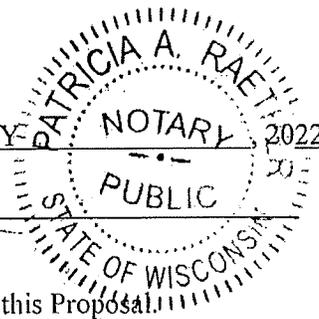

Contract 8586 – Bachmann Construction Company, Inc.

Section F: Best Value Contracting (BVC) Form

This section is a required document for the bid to be considered complete. There are two methods for completing the Best Value Contracting (BVC) form. Method one: The form can be filled out online and submitted to this site to be included with your electronic bid. Method two: The form can be downloaded from the site and submitted by hand to the City of Madison.

Method of Submittal of Best Value Contracting form (click in box below to choose) *
I will submit Bid Express fillable online form (BVC).

Best Value Contracting

None

2. Madison General Ordinance (M.G.O.), 33.07(7), does provide for some exemptions from the active apprentice requirement. Apprenticeable trades are those trades considered apprenticeable by the State of Wisconsin. Please check applicable box if you are seeking an exemption.

- Contractor has a total skilled workforce of four or less individuals in all apprenticeable trades combined.
- No available trade training program; The Contractor has been rejected by the only available trade training program, or there is no trade training program within 90 miles.
- Contractor is not using an apprentice due to having a journey worker on layoff status, provided the journey worker was employed by the contractor in the past six months.
- First time contractor on City of Madison Public Works contract requests a onetime exemption but intends to comply on all future contracts and is taking steps typical of a "good faith" effort.
- Contractor has been in business less than one year.
- Contractor doesn't have enough journeyman trade workers to qualify for a trade training program in that respective trade.

3. The Contractor shall indicate on the following section which apprenticeable trades are to be used on this contract. Compliance with active apprenticeship, to the extent required by M.G.O. 33.07(7), shall be satisfied by documentation from an applicable trade training body; an apprenticeship contract with the Wisconsin Department of Workforce Development or a similar agency in another state; or the U.S Department of Labor. This documentation is required prior to the Contractor beginning work on the project site.

- The Contractor has reviewed the list and shall not use any apprenticeable trades on this project.

LIST APPRENTICABLE TRADES (check all that apply to your work to be performed on this contract)

- BRICKLAYER
- CARPENTER
- CEMENT MASON / CONCRETE FINISHER
- CEMENT MASON (HEAVY HIGHWAY)
- CONSTRUCTION CRAFT LABORER
- DATA COMMUNICATION INSTALLER
- ELECTRICIAN
- ENVIRONMENTAL SYSTEMS TECHNICIAN / HVAC SERVICE TECH/HVAC INSTALL / SERVICE
- GLAZIER
- HEAVY EQUIPMENT OPERATOR / OPERATING ENGINEER
- INSULATION WORKER (HEAT and FROST)
- IRON WORKER
- IRON WORKER (ASSEMBLER, METAL BLDGS)
- PAINTER and DECORATOR
- PLASTERER
- PLUMBER
- RESIDENTIAL ELECTRICIAN
- ROOFER and WATER PROOFER
- SHEET METAL WORKER
- SPRINKLER FITTER
- STEAMFITTER
- STEAMFITTER (REFRIGERATION)
- STEAMFITTER (SERVICE)
- TAPER and FINISHER
- TELECOMMUNICATIONS (VOICE, DATA and VIDEO) INSTALLER-TECHNICIAN
- TILE SETTER

REINDAHL RESTROOM REMODEL

CONTRACT NO. 8586

DATE: 7/14/22

**Bachmann Construction
Company, Inc.**

Item	Quantity	Price	Extension
Section B: Proposal Page			
90000 - Conversion and Remodel of concessions room into two single use restrooms and a small mechanical room in the Reindahl Park Splash Pad Pump/Concession Building - Lump Sum	1.00	\$139,598.00	\$139,598.00
1 Items	Totals		\$139,598.00

IN WITNESS WHEREOF, the Principal and the Surety have hereunto set their hands and seals, and such of them as are corporations have caused their corporate seals to be hereto affixed and these presents to be signed by their proper officers, on the day and year set forth below.

PRINCIPAL

Bachmann Construction Company, Inc. 1-4-2022
COMPANY NAME AFFIX SEAL DATE
By: *P.A. Bachmann* PRES
SIGNATURE AND TITLE

SURETY

Old Republic Surety Company 1-4-2022
COMPANY NAME AFFIX SEAL DATE
By: *E. Mosca*
SIGNATURE AND TITLE Elizabeth Mosca, Attorney-in-Fact

This certifies that I have been duly licensed as an agent for the Surety in Wisconsin under National Provider No. 12305256 for the year 2022 and appointed as attorney in fact with authority to execute this bid bond, which power of attorney has not been revoked.

1-4-2022
DATE

E. Mosca
AGENT SIGNATURE

PO Box 259408
ADDRESS

Madison, WI 53725-9408
CITY, STATE AND ZIP CODE

608-252-9674
TELEPHONE NUMBER

Note to Surety and Principal: Any bid submitted which this bond guarantees may be rejected if the Power of Attorney form showing that the Agent of Surety is currently authorized to execute bonds on behalf of Surety is not attached to this bond.



OLD REPUBLIC SURETY COMPANY

POWER OF ATTORNEY

KNOW ALL MEN BY THESE PRESENTS: That OLD REPUBLIC SURETY COMPANY, a Wisconsin stock insurance corporation, does make, constitute and appoint:

Judith A. Walker, Patrick A. McKenna, Brooke L. Parker, Elizabeth Mosca, David Zenobi, Kathryn A. Weidner, Jay A. Zahn of Madison, WI

its true and lawful Attorney(s)-in-Fact, with full power and authority for and on behalf of the company as surety, to execute and deliver and affix the seal of the company thereto (if a seal is required), bonds, undertakings, recognizances or other written obligations in the nature thereof, (other than bail bonds, bank depository bonds, mortgage deficiency bonds, mortgage guaranty bonds, guarantees of installment paper and note guaranty bonds, self-insurance workers compensation bonds guaranteeing payment of benefits, or black lung bonds), as follows:

ALL WRITTEN INSTRUMENTS

and to bind OLD REPUBLIC SURETY COMPANY thereby, and all of the acts of said Attorneys-in-Fact, pursuant to these presents, are ratified and confirmed. This appointment is made under and by authority of the board of directors at a special meeting held on February 18, 1982.

This Power of Attorney is signed and sealed by facsimile under and by the authority of the following resolutions adopted by the board of directors of the OLD REPUBLIC SURETY COMPANY on February 18, 1982.

RESOLVED that, the president, any vice-president or assistant vice president, in conjunction with the secretary or any assistant secretary, may appoint attorneys-in-fact or agents with authority as defined or limited in the instrument evidencing the appointment in each case, for and on behalf of the company to execute and deliver and affix the seal of the company to bonds, undertakings, recognizances, and suretyship obligations of all kinds; and said officers may remove any such attorney-in-fact or agent and revoke any Power of Attorney previously granted to such person.

RESOLVED FURTHER, that any bond, undertaking, recognizance, or suretyship obligation shall be valid and binding upon the Company

- (i) when signed by the president, any vice president or assistant vice president, and attested and sealed (if a seal be required) by any secretary or assistant secretary; or
- (ii) when signed by the president, any vice president or assistant vice president, secretary or assistant secretary, and countersigned and sealed (if a seal be required) by a duly authorized attorney-in-fact or agent; or
- (iii) when duly executed and sealed (if a seal be required) by one or more attorneys-in-fact or agents pursuant to and within the limits of the authority evidenced by the Power of Attorney issued by the company to such person or persons.

RESOLVED FURTHER that the signature of any authorized officer and the seal of the company may be affixed by facsimile to any Power of Attorney or certification thereof authorizing the execution and delivery of any bond, undertaking, recognizance, or other suretyship obligations of the company; and such signature and seal when so used shall have the same force and effect as though manually affixed.

IN WITNESS WHEREOF, OLD REPUBLIC SURETY COMPANY has caused these presents to be signed by its proper officer, and its corporate seal to be affixed this 22nd day of February, 2021.

Karen J. Haffner
Assistant Secretary



OLD REPUBLIC SURETY COMPANY

Alan Pavlic
President

STATE OF WISCONSIN, COUNTY OF WAUKESHA - SS

On this 22nd day of February, 2021, personally came before me, Alan Pavlic and Karen J Haffner, to me known to be the individuals and officers of the OLD REPUBLIC SURETY COMPANY who executed the above instrument, and they each acknowledged the execution of the same, and being by me duly sworn, did severally depose and say: that they are the said officers of the corporation aforesaid, and that the seal affixed to the above instrument is the seal of the corporation, and that said corporate seal and their signatures as such officers were duly affixed and subscribed to the said instrument by the authority of the board of directors of said corporation.



Kathryn R. Pearson
Notary Public

My Commission Expires: September 28, 2022

(Expiration of notary's commission does not invalidate this instrument)

CERTIFICATE

I, the undersigned, assistant secretary of the OLD REPUBLIC SURETY COMPANY, a Wisconsin corporation, CERTIFY that the foregoing and attached Power of Attorney remains in full force and has not been revoked; and furthermore, that the Resolutions of the board of directors set forth in the Power of Attorney, are now in force.

24 3933



Signed and sealed at the City of Brookfield, WI this 4th day of January, 2022.

Karen J. Haffner
Assistant Secretary

ORSC 22262 (3-08)

SECTION H: AGREEMENT

THIS AGREEMENT made this 3rd day of August in the year Two Thousand and Twenty-Two between BACHMANN CONSTRUCTION COMPANY, INC. hereinafter called the Contractor, and the City of Madison, Wisconsin, hereinafter called the City.

WHEREAS, the Common Council of the said City of Madison under the provisions of a resolution adopted AUGUST 2, 2022, and by virtue of authority vested in the said Council, has awarded to the Contractor the work of performing certain construction.

NOW, THEREFORE, the Contractor and the City, for the consideration hereinafter named, agree as follows:

1. **Scope of Work.** The Contractor shall, perform the construction, execution and completion of the following listed complete work or improvement in full compliance with the Plans, Specifications, Standard Specifications, Supplemental Specifications, Special Provisions and contract; perform all items of work covered or stipulated in the proposal; perform all altered or extra work; and shall furnish, unless otherwise provided in the contract, all materials, implements, machinery, equipment, tools, supplies, transportation, and labor necessary to the prosecution and completion of the work or improvements:

REINDAHL RESTROOM REMODEL CONTRACT NO. 8586

2. **Completion Date/Contract Time.** Construction work must begin within seven (7) calendar days after the date appearing on mailed written notice to do so shall have been sent to the Contractor and shall be carried on at a rate so as to secure full completion SEE SPECIAL PROVISIONS, the rate of progress and the time of completion being essential conditions of this Agreement.
3. **Contract Price.** The City shall pay to the Contractor at the times, in the manner and on the conditions set forth in said specifications, the sum of ONE HUNDRED THIRTY-NINE THOUSAND FIVE HUNDRED NINETY-EIGHT AND NO/100 (\$139,598.00) Dollars being the amount bid by such Contractor and which was awarded to him/her as provided by law.
4. **Affirmative Action.** In the performance of the services under this Agreement the Contractor agrees not to discriminate against any employee or applicant because of race, religion, marital status, age, color, sex, disability, national origin or ancestry, income level or source of income, arrest record or conviction record, less than honorable discharge, physical appearance, sexual orientation, gender identity, political beliefs, or student status. The Contractor further agrees not to discriminate against any subcontractor or person who offers to subcontract on this contract because of race, religion, color, age, disability, sex, sexual orientation, gender identity or national origin.

The Contractor agrees that within thirty (30) days after the effective date of this agreement, the Contractor will provide to the City Affirmative Action Division certain workforce utilization statistics, using a form to be furnished by the City.

If the contract is still in effect, or if the City enters into a new agreement with the Contractor, within one year after the date on which the form was required to be provided, the Contractor will provide updated workforce information using a second form, also to be furnished by the City. The second form will be submitted to the City Affirmative Action Division no later than one year after the date on which the first form was required to be provided.

The Contractor further agrees that, for at least twelve (12) months after the effective date of this contract, it will notify the City Affirmative Action Division of each of its job openings at facilities in Dane County for which applicants not already employees of the Contractor are to be considered. The notice will include a job description, classification, qualifications and application procedures

and deadlines. The Contractor agrees to interview and consider candidates referred by the Affirmative Action Division if the candidate meets the minimum qualification standards established by the Contractor, and if the referral is timely. A referral is timely if it is received by the Contractor on or before the date started in the notice.

Articles of Agreement
Article I

The Contractor shall take affirmative action in accordance with the provisions of this contract to insure that applicants are employed, and that employees are treated during employment without regard to race, religion, color, age, marital status, disability, sex, sexual orientation, gender identity or national origin and that the employer shall provide harassment free work environment for the realization of the potential of each employee. Such action shall include, but not be limited to, the following: employment, upgrading, demotion or transfer, recruitment or recruitment advertising, layoff or termination, rates of pay or other forms of compensation and selection for training including apprenticeship insofar as it is within the control of the Contractor. The Contractor agrees to post in conspicuous places available to employees and applicants notices to be provided by the City setting out the provisions of the nondiscrimination clauses in this contract.

Article II

The Contractor shall in all solicitations or advertisements for employees placed by or on behalf of the Contractors state that all qualified or qualifiable applicants will be employed without regard to race, religion, color, age, marital status, disability, sex, sexual orientation, gender identity or national origin.

Article III

The Contractor shall send to each labor union or representative of workers with which it has a collective bargaining agreement or other contract or understanding a notice to be provided by the City advising the labor union or worker's representative of the Contractor's equal employment opportunity and affirmative action commitments. Such notices shall be posted in conspicuous places available to employees and applicants for employment.

Article V

The Contractor agrees that it will comply with all provisions of the Affirmative Action Ordinance of the City of Madison, including the contract compliance requirements. The Contractor agrees to submit the model affirmative action plan for public works contractors in a form approved by the Affirmative Action Division Manager.

Article VI

The Contractor will maintain records as required by Section 39.02(9)(f) of the Madison General Ordinances and will provide the City Affirmative Action Division with access to such records and to persons who have relevant and necessary information, as provided in Section 39.02(9)(f). The City agrees to keep all such records confidential, except to the extent that public inspection is required by law.

Article VII

In the event of the Contractor's or subcontractor's failure to comply with the Equal Employment Opportunity and Affirmative Action Provisions of this contract or Section 39.03 and 39.02 of the Madison General Ordinances, it is agreed that the City at its option may do any or all of the following:

1. Cancel, terminate or suspend this Contract in whole or in part.

2. Declare the Contractor ineligible for further City contracts until the Affirmative Action requirements are met.
3. Recover on behalf of the City from the prime Contractor 0.5 percent of the contract award price for each week that such party fails or refuses to comply, in the nature of liquidated damages, but not to exceed a total of five percent (5%) of the contract price, or ten thousand dollars (\$10,000), whichever is less. Under public works contracts, if a subcontractor is in noncompliance, the City may recover liquidated damages from the prime Contractor in the manner described above. The preceding sentence shall not be construed to prohibit a prime Contractor from recovering the amount of such damage from the non-complying subcontractor.

Article VIII

The Contractor shall include the above provisions of this contract in every subcontract so that such provisions will be binding upon each subcontractor. The Contractor shall take such action with respect to any subcontractor as necessary to enforce such provisions, including sanctions provided for noncompliance.

Article IX

The Contractor shall allow the maximum feasible opportunity to small business enterprises to compete for any subcontracts entered into pursuant to this contract. (In federally funded contracts the terms "DBE, MBE and WBE" shall be substituted for the term "small business" in this Article.)

5. Substance Abuse Prevention Program Required. Prior to commencing work on the Contract, the Contractor, and any Subcontractor, shall have in place a written program for the prevention of substance abuse among its employees as required under Wis. Stat. Sec. 103.503.
6. **Contractor Hiring Practices.**

Ban the Box - Arrest and Criminal Background Checks. (Sec. 39.08, MGO)

This provision applies to all prime contractors on contracts entered into on or after January 1, 2016, and all subcontractors who are required to meet prequalification requirements under MGO 33.07(7)(I), MGO as of the first time they seek or renew pre-qualification status on or after January 1, 2016. The City will monitor compliance of subcontractors through the pre-qualification process.

- a. **Definitions.** For purposes of this section, "Arrest and Conviction Record" includes, but is not limited to, information indicating that a person has been questioned, apprehended, taken into custody or detention, held for investigation, arrested, charged with, indicted or tried for any felony, misdemeanor or other offense pursuant to any law enforcement or military authority.

"Conviction record" includes, but is not limited to, information indicating that a person has been convicted of a felony, misdemeanor or other offense, placed on probation, fined, imprisoned or paroled pursuant to any law enforcement or military authority.

"Background Check" means the process of checking an applicant's arrest and conviction record, through any means.

- b. **Requirements.** For the duration of this Contract, the Contractor shall:

1. Remove from all job application forms any questions, check boxes, or other inquiries regarding an applicant's arrest and conviction record, as defined herein.

2. Refrain from asking an applicant in any manner about their arrest or conviction record until after conditional offer of employment is made to the applicant in question.
3. Refrain from conducting a formal or informal background check or making any other inquiry using any privately or publicly available means of obtaining the arrest or conviction record of an applicant until after a conditional offer of employment is made to the applicant in question.
4. Make information about this ordinance available to applicants and existing employees, and post notices in prominent locations at the workplace with information about the ordinance and complaint procedure using language provided by the City.
5. Comply with all other provisions of Sec. 39.08, MGO.

c. Exemptions: This section shall not apply when:

1. Hiring for a position where certain convictions or violations are a bar to employment in that position under applicable law, or
2. Hiring a position for which information about criminal or arrest record, or a background check is required by law to be performed at a time or in a manner that would otherwise be prohibited by this ordinance, including a licensed trade or profession where the licensing authority explicitly authorizes or requires the inquiry in question.

To be exempt, Contractor has the burden of demonstrating that there is an applicable law or regulation that requires the hiring practice in question, if so, the contractor is exempt from all of the requirements of this ordinance for the position(s) in question.

**REINDAHL RESTROOM REMODEL
CONTRACT NO. 8586**

IN WITNESS WHEREOF, the Contractor has hereunto set his/her hand and seal and the City has caused this contract to be sealed with its corporate seal and to be executed by its Mayor and City Clerk on the dates written below.

Countersigned:

BACHMANN CONSTRUCTION COMPANY, INC.

Robert Roth 8/3/22
Witness Date
Yvonne A. Fetters 8/3/22
Witness Date

Company Name
[Signature] 8/3/22
President A.C. Bachmann Date
Sheryl Moreland 8/3/22
Secretary Date

CITY OF MADISON, WISCONSIN

Provisions have been made to pay the liability that will accrue under this contract.

Approved as to form:

Michael Hays 8.15.2022
Finance Director Date
[Signature] 8/17/22
Witness Date
[Signature] 8-10-2022
Witness Date

Michael Hays 8/17/22
City Attorney Date
[Signature] 8/17/22
Mayor Date
Theresa Lund for 8/10/22
City Clerk Date

SECTION I: PAYMENT AND PERFORMANCE BOND

LET ALL KNOW BY THESE DOCUMENTS PRESENTED, that we **BACHMANN CONSTRUCTION COMPANY, INC.** as principal, and Old Republic Surety Company Company of Wisconsin as surety, are held and firmly bound unto the City of Madison, Wisconsin, in the sum of **ONE HUNDRED THIRTY-NINE THOUSAND FIVE HUNDRED NINETY-EIGHT AND NO/100 (\$139,598.00)** Dollars, lawful money of the United States, for the payment of which sum to the City of Madison, we hereby bind ourselves and our respective executors and administrators firmly by these presents.

The condition of this Bond is such that if the above bounden shall on his/her part fully and faithfully perform all of the terms of the Contract entered into between him/herself and the City of Madison for the construction of:

**REINDAHL RESTROOM REMODEL
CONTRACT NO. 8586**

in Madison, Wisconsin, and shall pay all claims for labor performed and material furnished in the prosecution of said work, and save the City harmless from all claims for damages because of negligence in the prosecution of said work, and shall save harmless the said City from all claims for compensation (under Chapter 102, Wisconsin Statutes) of employees and employees of subcontractor, then this Bond is to be void, otherwise of full force, virtue and effect.

Signed and sealed this 3rd day of August, 2022

Countersigned:

[Signature]
Witness

[Signature]
Secretary

BACHMANN CONSTRUCTION COMPANY, INC.
Company Name (Principal)
[Signature]
President Seal ~~NONE~~

Approved as to form:

[Signature]
City Attorney

Old Republic Surety Company
Surety Seal
 Salary Employee Commission
By [Signature]
Attorney-in-Fact Patrick A. McKenna

This certifies that I have been duly licensed as an agent for the above company in Wisconsin under National Producer Number 650765 for the year 2022, and appointed as attorney-in-fact with authority to execute this payment and performance bond which power of attorney has not been revoked.

August 3, 2022
Date

[Signature]
Agent Signature



OLD REPUBLIC SURETY COMPANY

POWER OF ATTORNEY

KNOW ALL MEN BY THESE PRESENTS: That OLD REPUBLIC SURETY COMPANY, a Wisconsin stock insurance corporation, does make, constitute and appoint: JUDITH A. WALKER, PATRICK A. MCKENNA, BROOKE L. PARKER, DAVID ZENOBI, KATHRYN A. WEIDNER, JAY A. ZAHN, JENNY L. HIRTH, LYNN E. POTTER

of MADISON, WI

its true and lawful Attorney(s)-in-Fact, with full power and authority for and on behalf of the company as surety, to execute and deliver and affix the seal of the company thereto (if a seal is required), bonds, undertakings, recognizances or other written obligations in the nature thereof, (other than bail bonds, bank depository bonds, mortgage deficiency bonds, mortgage guaranty bonds, guarantees of installment paper and note guaranty bonds, self-insurance workers compensation bonds guaranteeing payment of benefits, or black lung bonds), as follows:

ALL WRITTEN INSTRUMENTS

and to bind OLD REPUBLIC SURETY COMPANY thereby, and all of the acts of said Attorneys-in-Fact, pursuant to these presents, are ratified and confirmed. This appointment is made under and by authority of the board of directors at a special meeting held on February 18, 1982.

This Power of Attorney is signed and sealed by facsimile under and by the authority of the following resolutions adopted by the board of directors of the OLD REPUBLIC SURETY COMPANY on February 18, 1982.

RESOLVED that, the president, any vice-president or assistant vice president, in conjunction with the secretary or any assistant secretary, may appoint attorneys-in-fact or agents with authority as defined or limited in the instrument evidencing the appointment in each case, for and on behalf of the company to execute and deliver and affix the seal of the company to bonds, undertakings, recognizances, and suretyship obligations of all kinds; and said officers may remove any such attorney-in-fact or agent and revoke any Power of Attorney previously granted to such person.

RESOLVED FURTHER, that any bond, undertaking, recognizance, or suretyship obligation shall be valid and binding upon the Company

- (i) when signed by the president, any vice president or assistant vice president, and attested and sealed (if a seal be required) by any secretary or assistant secretary; or
- (ii) when signed by the president, any vice president or assistant vice president, secretary or assistant secretary, and countersigned and sealed (if a seal be required) by a duly authorized attorney-in-fact or agent; or
- (iii) when duly executed and sealed (if a seal be required) by one or more attorneys-in-fact or agents pursuant to and within the limits of the authority evidenced by the Power of Attorney issued by the company to such person or persons.

RESOLVED FURTHER that the signature of any authorized officer and the seal of the company may be affixed by facsimile to any Power of Attorney or certification thereof authorizing the execution and delivery of any bond, undertaking, recognizance, or other suretyship obligations of the company; and such signature and seal when so used shall have the same force and effect as though manually affixed.

IN WITNESS WHEREOF, OLD REPUBLIC SURETY COMPANY has caused these presents to be signed by its proper officer, and its corporate seal to be affixed this 18th day of May, 2022.

OLD REPUBLIC SURETY COMPANY

Karen J. Haffner
Assistant Secretary



Alan Pavlic
President

STATE OF WISCONSIN, COUNTY OF WAUKESHA - SS

On this 18th day of May, 2022, personally came before me, Alan Pavlic and Karen J Haffner, to me known to be the individuals and officers of the OLD REPUBLIC SURETY COMPANY who executed the above instrument, and they each acknowledged the execution of the same, and being by me duly sworn, did severally depose and say: that they are the said officers of the corporation aforesaid, and that the seal affixed to the above instrument is the seal of the corporation, and that said corporate seal and their signatures as such officers were duly affixed and subscribed to the said instrument by the authority of the board of directors of said corporation.



Kathryn R. Pearson
Notary Public

My Commission Expires: September 28, 2022

(Expiration of notary's commission does not invalidate this instrument)

CERTIFICATE

I, the undersigned, assistant secretary of the OLD REPUBLIC SURETY COMPANY, a Wisconsin corporation, CERTIFY that the foregoing and attached Power of Attorney remains in full force and has not been revoked; and furthermore, that the Resolutions of the board of directors set forth in the Power of Attorney, are now in force.



24-3933

Signed and sealed at the City of Brookfield, WI this 3rd day of August, 2022.

Karen J. Haffner
Assistant Secretary

ORSC 22262 (3-06)

